



# Guide to Operations

***innova*<sup>™</sup> 2100/2150**

**Digital Platform Shaker**

MANUAL NO: M1194-0050

Revision N

August 20, 2002

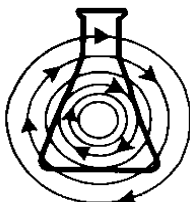

**NEW BRUNSWICK SCIENTIFIC CO., INC.**

BOX 4005 • 44 TALMADGE ROAD • EDISON, NJ 08818-4005

Telephone: 1-732-287-1200 • 1-800-631-5417

Fax: 732-287-4222 • Telex: 4753012 NBSCO

Internet: <http://www.nbsc.com> • E-mail: [bioinfo@nbsc.com](mailto:bioinfo@nbsc.com)

---



---

## **INTERNATIONAL OFFICES:**

### **THE NETHERLANDS**

New Brunswick Scientific BV  
Kerkenbos 1101, 6546 BC Nijmegen  
P.O Box 6826, 6503 GH Nijmegen  
Holland  
Tel: 31 (0)24 3717 600  
Fax: 31 (0)24 3717 640  
E-mail: sales@nbsbv.nl

### **FRANCE**

New Brunswick Scientific SARL  
3, rue des Deux-Boules  
75001 Paris  
France  
Tel: 33 (0)1 4026 2246  
Fax: 33 (0)1 4026 5423  
E-mail: sales@nbssarl.fr

### **UNITED KINGDOM**

New Brunswick Scientific (UK) Ltd.  
Edison House, 163 Dixons Hill Road  
North Mymms, Hatfield, Herts. AL9 7JE  
United Kingdom  
Tel: 44 (0)1707 275733  
Fax: 44 (0)1707 267859  
E-mail: bioinfo@nbsuk.co.uk

### **BELGIUM**

New Brunswick Scientific NV/SA  
't Veldeke 1  
B-1970 Wezembeek-Oppem  
België/Belgique  
Tel: 32 (0)2 731 6787  
Fax: 32 (0)2 731 8130  
E-mail: sales@nbsnv-sa.be

### **GERMANY**

New Brunswick Scientific GmbH  
In Der Au 14  
D-72622 Nürtingen  
Deutschland  
Tel: 49 (0)7022 932490  
Fax: 49 (0)7022 32486  
E-mail: sales@nbsgmbh.de

### **CHINA**

New Brunswick Scientific Co., Inc.  
9A. AiBang Building  
585 LingLing Road  
Shanghai 200030, P.R. China  
Tel: 86 21 6481 2658  
Fax: 86 21 6481 2665  
E-mail: nbschc@online.sh.cn

**THIS PAGE INTENTIONALLY BLANK**

**CAUTION!**

This equipment *must* be operated as described in this manual. If operational guidelines are not followed, equipment damage and personal injury *can* occur.

Please read the entire User's Guide before attempting to use this unit.

Do not use this equipment in a hazardous atmosphere or with hazardous materials for which the equipment was not designed.

New Brunswick Scientific Co., Inc. (NBS) is not responsible for any damage to this equipment that may result from the use of an accessory not manufactured by NBS.

**THIS PAGE INTENTIONALLY BLANK**

## Copyright Notice

New Brunswick Scientific Company, Inc.  
Box 4005 44 Talmadge Road  
Edison, New Jersey 08818-4005

© Copyright 2002 New Brunswick Scientific Co., Inc.

All Rights Reserved.

Reproduction, adaptation, or translation without prior written permission from New Brunswick Scientific is prohibited.

## Disclaimer Notice

New Brunswick Scientific Co., Inc. reserves the right to change information in this document without notice. Updates to information in this document reflect our commitment to continuing product development and improvement.

## Manual Conventions



### NOTE:

Notes contain essential information that deserves special attention.



### CAUTION!

*Caution* messages appear before procedures which, if caution is not observed, could result in damage to the equipment.



### WARNING!

*Warning* messages alert you to specific procedures or practices which, if not followed correctly, could result in serious personal injury.

### **Bold**

Text in bold face type emphasizes key words or phrases.

**THIS PAGE INTENTIONALLY BLANK**





## WARRANTY

Every Instrument manufactured by the New Brunswick Scientific Co., Inc. is warranted to be free from defects in material and workmanship. This apparatus is warranted for 2 years or 10,000 hours (whichever comes later) against faulty components and assembly and our obligation under this warranty is limited to repairing or replacing the instrument or part thereof, which shall within 2 years or 10,000 hours (whichever comes later) after the date of shipment, prove to be defective after our examination. This warranty does not extend to any NBS products which have been subjected to misuse, neglect, accident or improper installation or application; nor shall it extend to products which have been repaired or altered outside the NBS factory without prior authorization from New Brunswick Scientific Co., Inc.

**THIS PAGE INTENTIONALLY BLANK**

## TABLE OF CONTENTS

<b>1</b>	<b>OVERVIEW .....</b>	<b>13</b>
<b>2</b>	<b>FEATURES.....</b>	<b>15</b>
2.1	GENERAL DESCRIPTION.....	15
2.2	UNIVERSAL POWER MODULE.....	16
2.3	CONTROL PANEL .....	16
2.3.1	<i>LED Display</i> .....	17
2.3.2	<i>Keypad</i> .....	17
2.3.3	<i>Status Indicator Lights</i> .....	18
2.3.4	<i>Function Indicator Lights</i> .....	18
2.4	PLATFORM ASSEMBLIES.....	18
2.5	OPTIONAL FEATURES .....	19
2.5.1	<i>Temperature/Monitor Option</i> .....	19
2.5.2	<i>Capacity Upgrade Option for 2100</i> .....	19
2.5.3	<i>Quick Change Platform Option</i> .....	19
2.6	HEAVY DUTY CONSTRUCTION .....	20
2.6.1	<i>Bearings</i> .....	20
2.6.2	<i>Motor</i> .....	21
2.7	ELECTRONIC BOARDS.....	21
<b>3</b>	<b>INSTALLATION .....</b>	<b>23</b>
3.1	UNPACKING.....	23
3.2	CHECKING VOLTAGE CONFIGURATION .....	23
3.3	SPACE REQUIREMENTS.....	23
3.4	ELECTRICAL CONNECTIONS .....	25
3.5	INSTALLING THE PLATFORM.....	25
3.5.1	<i>Quick Change Option</i> .....	25
3.6	CLAMP INSTALLATION .....	26
<b>4</b>	<b>OPERATION.....</b>	<b>27</b>
4.1	STARTING THE SHAKER .....	27
4.2	CONTINUOUS (UNLIMITED) RUN .....	27
4.3	CHECKING A SETPOINT.....	27
4.4	TIMED FUNCTIONS .....	28
4.4.1	<i>Setting the Timer</i> .....	28
4.4.2	<i>Stopping the Alarm</i> .....	28
4.4.3	<i>Cancelling the Timer</i> .....	28
4.5	ALARM FUNCTIONS .....	28
4.6	TOTAL RUNNING TIME .....	29
4.7	TEMPERATURE/MONITOR OPTION.....	29
4.8	RECORDER ADAPTATION.....	30
<b>5</b>	<b>MAINTENANCE .....</b>	<b>31</b>

---

5.1	CLEANING .....	31
<b>6</b>	<b>SERVICE .....</b>	<b>33</b>
6.1	REPLACING FUSES .....	33
6.2	CHANGING VOLTAGE .....	34
6.3	FUSING .....	35
6.3.1	<i>From Single to Double Fusing</i> .....	35
6.4	BELT REPLACEMENT .....	37
6.4.1	<i>Belt Adjustment</i> .....	40
6.5	MOTOR ASSEMBLY REPLACEMENT .....	41
6.6	TEMPERATURE/MONITOR OPTION .....	43
6.7	REPLACING ELECTRONIC BOARDS .....	45
6.7.1	<i>ESD Precautions</i> .....	45
6.8	CAPACITY UPGRADE OPTION .....	46
6.8.1	<i>Outrigger Kit</i> .....	47
6.9	QUICK CHANGE PLATFORM OPTION (INNOVA 2100) .....	48
6.9.1	<i>Removing the Quick Change Platform</i> .....	50
6.10	QUICK CHANGE PLATFORM OPTION (INNOVA 2150) .....	50
6.10.1	<i>Removing the Quick Change Platform</i> .....	51
6.11	MAINT INDICATOR .....	52
<b>7</b>	<b>PARTS &amp; ACCESSORIES .....</b>	<b>53</b>
7.1	SERVICE PARTS (2100/2150) .....	53
7.2	INNOVA 2100 INTERCHANGEABLE PLATFORMS .....	53
7.3	INNOVA 2150 INTERCHANGEABLE PLATFORMS .....	54
7.4	ACCESSORY FLASK CLAMPS .....	54
7.5	CLAMP MOUNTING HARDWARE KIT .....	54
7.5.1	<i>Hardware for 10 mL to 500 mL Clamps</i> .....	55
7.5.2	<i>Hardware for 1-Liter to 6-Liter Clamps</i> .....	55
7.6	OPTIONAL KITS .....	55
7.6.1	<i>Temperature/Monitor Option</i> .....	55
7.6.2	<i>Quick Change Platform Kit</i> .....	56
7.6.3	<i>Capacity Upgrade Option</i> .....	56
<b>8</b>	<b>SPECIFICATIONS .....</b>	<b>57</b>
<b>9</b>	<b>DRAWINGS .....</b>	<b>61</b>
9.1	CONTROL SCHEMATIC .....	61
9.2	DRAWING LIST .....	66
<b>10</b>	<b>INDEX .....</b>	<b>67</b>

# 1 OVERVIEW

The Innova 2100/2150 Digital Platform Shaker will provide you with reliable and maintenance-free operation which is characteristic of all NBS shakers. The Innova 2100/2150 models are among the newest generation of NBS shakers; they incorporate a variety of state-of-the-art components and features to permit the precision operation necessary for your exacting scientific experiments.

This manual is intended to provide a complete understanding of Innova 2100/2150 Digital Platform Shaker installation, operation, basic components, and basic preventive maintenance and service issues. This manual also includes a guide to key service procedures, intended for use only by authorized service technicians.

We recommend that you completely familiarize yourself with this manual prior to operating the Innova 2100/2150.

**THIS PAGE INTENTIONALLY BLANK**

## 2 FEATURES

### 2.1 General Description

The Innova 2100/2150 is a benchtop or floor shaker utilizing a triple eccentric counter- balanced drive to provide horizontal plane rotary motion in a 3/4 -inch (19mm) circular orbit. A Proportional/Integral (PI) Microprocessor controller with instantaneous digital feedback controls the speed over a range of 25-500 RPM.

The shaker may be operated either continuously or in a timed mode via a programmable timer for shaking periods of 0.1 hour to 99.9 hours. A temperature/ monitoring option is available for the measurement, display and documentation of sample temperature (*see Section 2.5.1 ,Temperature/Monitor Option*).

The Innova 2100/2150 is equipped with audible and visible alarms which are activated when an alarm condition exists, as follows:

- The end of a timed run
- Deviations of shaking speed outside of tolerance limits

A wide variety of platforms can be used with the Innova 2100/2150. Dedicated platforms are available for a variety of flask sizes. Universal platforms and utility trays are also available (*see Sections 7.2 and 7.3, Interchangeable Platforms*).

**Figure 1: Front View (2100/2150)**

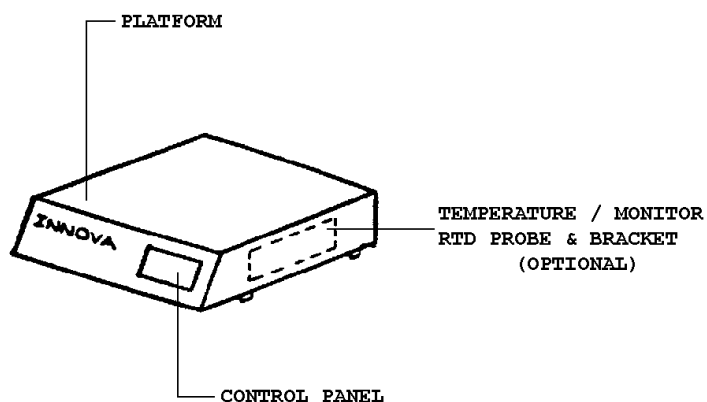

**Figure 2: Rear View (2100/2150)**

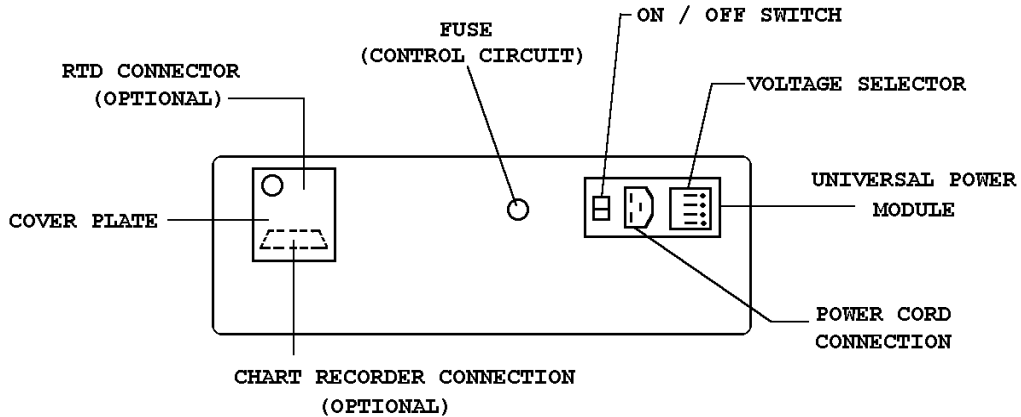

## 2.2 Universal Power Module

The power module contains a voltage card and fuse holder which are used to select the appropriate voltage and fusing. This universal power entry system adapts to worldwide power requirements. Voltage and fusing has been set prior to shipment. Innova shakers are available in 100V, 120V, 220V and 240V configurations that accommodate both 50 and 60 Hz frequencies.



### **WARNING!**

**Before you plug the unit into a power source, it is critical to check the voltage.**

**On the rear panel, confirm that the voltage setting is correct by checking the voltage indicator in the universal power module (Figure 2) and the voltage listed on the Caution label that is located over the power switch and power cord connection.**

## 2.3 Control Panel

The control panel (*see Figure 3*), located on the front of the instrument, serves as the operator interface. The keypad has four keys marked Start/Stop, ▲, ▼, and Select. A three-digit LED display provides numeric values as well as some letter codes. There are four **function indicator lights** and four **status indicator lights** on the control panel as well. A general description of the display, user interface keys and indicators follows. For operation of the control panel, *see Section 4*.



**Figure 3: Control Panel (2100/2150)**

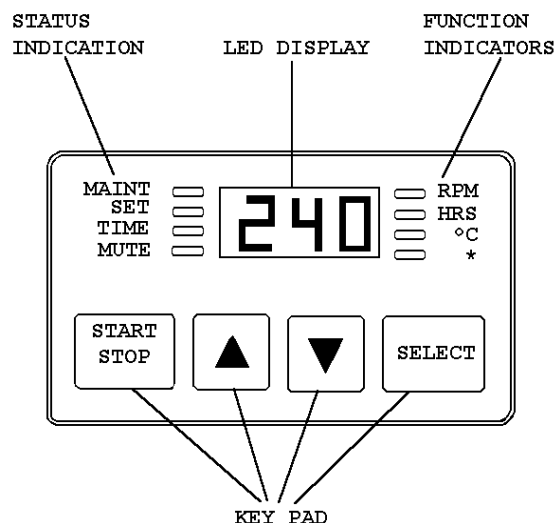

### 2.3.1 LED Display

The display on the Innova control panel is a three-digit LED display. During normal shaker operation, the display will indicate:

- Shaker status (on/off)
- Shaking speed
- Setpoints
- Hours remaining (timed run)
- Measured temperature (when temperature/monitor option is installed)

### 2.3.2 Keypad

There are four user interface keys on the keypad:

- START/STOP** This key is used to start or stop the shaking motion. It will also activate or stop the timer when a timed run is desired.
- SELECT** This key is used to change the displayed parameter. Temperature (°C) cannot be selected unless the temperature/remote monitoring option is installed.
- ▲ and ▼** These keys are used to adjust the setpoint of a displayed parameter up or down. They also allow the user to enter the Set mode for setpoint changes.

### 2.3.3 Status Indicator Lights

Four status indicator lights are located to the left of the LED display:

<b>MAINT</b>	Remains lit after 10,000 hours of use. Accumulated running time is internally monitored and may be displayed as a guideline.
<b>SET</b>	Indicates that the shaker is in the Set mode and setpoints are being displayed and can be altered.
<b>TIME</b>	Indicates that the timer is in operation. Innova shakers can be programmed to run for a preset time from 0.1 hour to 99.9 hours. The timer can be disengaged.
<b>MUTE</b>	Indicates the status of the audible alarm. When the Mute indicator is illuminated the audible alarm device is disabled.

### 2.3.4 Function Indicator Lights

Four function indicator lights are located to the right of the LED display. They indicate the current parameter being displayed:

<b>RPM</b>	Revolutions per minute
<b>HRS</b>	Time remaining in a timed run
<b>°C</b>	The temperature function will be activated only if the temperature/monitor option is installed.
*	Not applicable to the Innova 2100/2150

## 2.4 Platform Assemblies

The Innova 2100 can be used with a wide variety of NBS 18" x 18" (46cm x 46cm) platforms which will accept a variety of clamps for flasks, test tubes, etc. (*see Section 7.2*).

The Innova 2150 can accommodate a wide variety of NBS 18" x 24" (46cm x 61cm) platforms which will accept a variety of clamps for flasks, test tubes, etc. (*see Section 7.3*).

---

## 2.5 **Optional Features**

### 2.5.1 **Temperature/Monitor Option**

A Temperature/Monitor Option is available (NBS part number M1194-9924) for installation on the Innova 2100/2150. The temperature of liquid in any vessel or the ambient temperature can be measured using the RTD electronics-based measuring device supplied with this option. When the option is installed, the LED will display the measured temperatures in 0.1°C increments.

This option also allows the connection of a chart recorder so that temperature and shaking speed can be documented. The analog output for shaking speed is 0-5V, 1V per 100 RPM. For temperature, the output is 0-5V with .05V per °C. The output can also be connected to a data logging computer with an analog data acquisition card.

### 2.5.2 **Capacity Upgrade Option for 2100**

It is possible to significantly increase the capacity of your Innova 2100 Shaker with an available capacity upgrade package (NBS part number M1194-9926). This option will convert an Innova 2100 to an Innova 2150 simply and easily.

This package consists of appropriate counterweights, outrigger feet and hardware. Large capacity Innova 2150 platforms **must** be used with the Innova 2150 configuration. For a listing of available platforms, see Sections 7.2 and 7.3.

### 2.5.3 **Quick Change Platform Option**

This accessory enables the user to snap in platforms without tools or hardware. This is especially handy for those users who change platforms frequently. The kit includes a subplatform with spring clips, an extra counterweight, and hardware for installation. This option is available for both the Innova 2100 and the Innova 2150. *See Sections 6.9 and 6.10 for details.*

A speed range of 25-400 RPM is recommended when this option is installed.

## 2.6 Heavy Duty Construction

The Triple Eccentric Drive used in Innova shakers employs the same proven technology which has driven New Brunswick Scientific's shakers for over 30 years. This drive mechanism (*see Figure 4*) utilizes a counterweight system to stabilize the rotary motion produced during operation. When the work load moves in one direction, opposing forces are generated to stabilize the shaker. This action will help eliminate the problem of "walking" which may occur with less precisely balanced instruments. Vibration is minimized and the life of the unit is extended.

**Figure 4: Counterbalanced Drive Mechanism (2100/2150)**

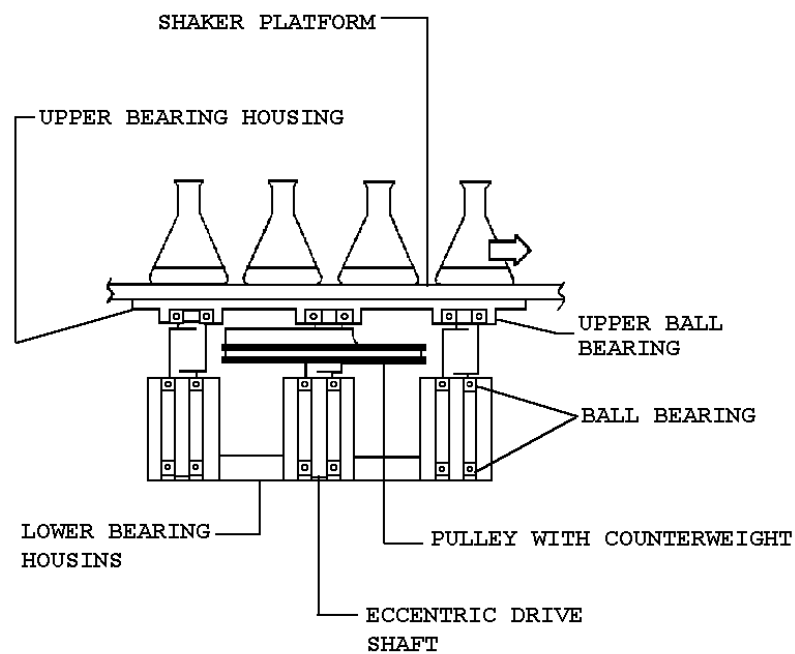

### 2.6.1 Bearings

Innova shakers employ sealed lubricated ball bearings of the highest quality. Sealed bearings minimize the generation of airborne particulates which may be disadvantageous in clean rooms or controlled environment areas. Such bearings require no maintenance and have run reliably in New Brunswick Scientific shakers for many years.

## 2.6.2 Motor

The Innova 2100 and 2150 Shakers use a three-phase brushless ball bearing DC motor. This low profile motor provides high torque along with quiet, efficient operation and low maintenance. The rugged motor has a rating of 1/15 horsepower.

## 2.7 *Electronic Boards*

The main control board for the Innova shaker has the following functions:

- Storage of key parameters during power interruption in a non-volatile memory.
- Speed sensing, electronic commutation, and power control for the brushless DC drive motor.
- Maintenance of an elapsed running time clock.
- Shaker control and recognition of an expansion connector for option modules via integrated firmware.
- Provision of an operator interface via displays, audible alarm and connection to the keypad module (keypad buttons and display graphics).

The optional temperature module is designed to piggyback onto the main board via an expansion connector. It has the following functions:

- Control of analog power supplies.
- Signal conditioning of RTD sensor readings.
- Provision of remote monitoring capabilities by supplying analog outputs for speed and temperature which are compatible with chart recorders and analog data acquisition systems.

**THIS PAGE INTENTIONALLY BLANK**

## 3 INSTALLATION

### 3.1 *Unpacking*

Upon unpacking the unit, inspect it carefully for any apparent damage that may have occurred during transit. Immediately report any damage to the carrier and to the New Brunswick Scientific Service Department.

Do not discard the crate or packing material.

**VERY IMPORTANT:** There are two small plastic straps that hold the bearing housing in place for shipping. Be sure to remove these two straps before operation.

### 3.2 *Checking Voltage Configuration*

Do not plug your shaker into the power source until you determine that voltage of your unit (by checking the voltage indicator and label on the rear of the unit) matches your electrical service.



#### **NOTE:**

**Use of the Innova shakers requires a platform, which is a separate item. Available platforms are listed in this manual (see *Section 7, Parts & Accessories*).**

**The Innova 2100 uses 18-inch by 18-inch (46cm x 46cm) platforms. The Innova 2150 or Innova 2100 with the Capacity Upgrade package uses 18-inch by 24-inch (46cm x 61cm) platforms.**

### 3.3 *Space Requirements*

It is essential that the unit be situated in an area where there is sufficient space for the shaker and platform to clear walls and other potential obstructions during operation.

The dimensions, including a platform but excluding glassware, are:

<b>Model</b>	<b>Width</b>	<b>Depth</b>	<b>Height</b>
Innova 2100 without capacity upgrade	19 inches	21 $\frac{7}{8}$ inches	6 $\frac{3}{8}$ inches
	48 cm	55.5 cm	17 cm
Innova 2150 & Innova 2100 with capacity upgrade	24 inches	21 $\frac{1}{4}$ inches	6 $\frac{3}{8}$ inches
	48 cm	55.5 cm	17 cm

The effective surface area required for operation is:

<b>Model</b>	<b>Width</b>	<b>Depth</b>
Innova 2100 without capacity upgrade	22 inches	24 inches
	56 cm	61 cm
Innova 2150 & Innova 2100 with capacity upgrade	27 inches	24 inches
	68 $\frac{1}{2}$ cm	61 cm

**Figure 5a: Space Requirements, Innova 2100**

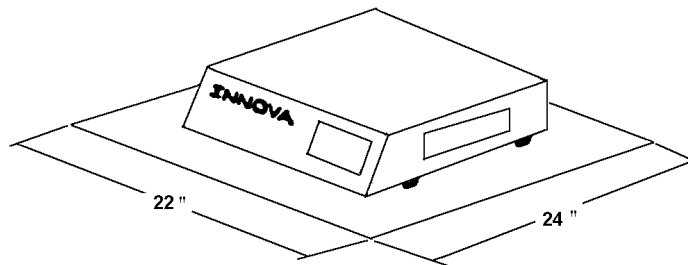

**Figure 5b: Space Requirements, Innova 2150/ Innova 2100 with Capacity Upgrade**

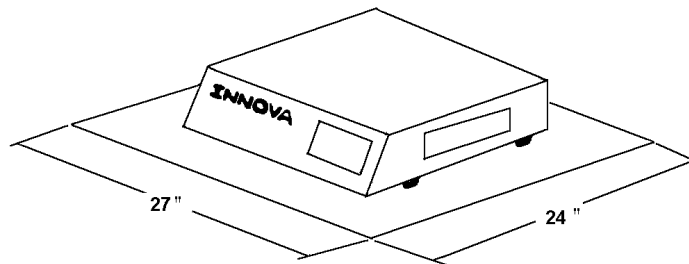



### 3.4 Electrical Connections

**CAUTION!**

Before making electrical connections, be sure to do the following:

1. Check that the power module at the rear of the unit is set to the correct voltage, corresponding to your power source. If it is not, refer to *Changing Voltage in Section 6.2*.
2. Remove the caution label from the universal power module.
3. Make sure the plastic straps have been removed from the upper bearing housing.
4. Make sure the power switch on the back of the unit is set in the OFF position.

**ONLY THEN:**

5. Connect the line cord to the power module and to a grounded electrical outlet.

**CAUTION!**

A grounded electrical outlet is necessary for the safe operation of this shaker.

### 3.5 Installing the Platform

A platform must be installed on the unit prior to use.

1. Set the power switch in the Off position.
2. Using the 7/32-inch hex wrench provided, remove the four Allen head platform screws installed in the subplatform of the bearing housing (under the shaker). One of the four screws has a tag so you can identify it. Set them aside for reuse.
3. Place the platform on top of the shaker's subplatform. Be sure to use the proper size platform for your particular model shaker (*see Section 7.2, Interchangeable Platforms*).
4. Reinstall and tighten the four platform screws (previously set aside) with the hex wrench to secure the platform.

#### 3.5.1 Quick Change Option

If the Quick Change Platform option (*see Section 7.6.2*) is installed:

1. Slip the appropriately sized platform between the side guides and push the platform to the rear retainer.
2. Press down on the front edge of the platform. The platform should snap down into place and be retained by the springs. Check that the rear edge of the platform is engaged under the bend of the rear clip.

### 3.6 Clamp Installation

Flask clamps purchased for use with universal platforms require installation. Clamps are installed by securing the base of the clamp to the platform. Flat head screws of different lengths and thread pitch are used. Consult the Flask Clamp Hardware reference tables in *Section 7.5* to identify the proper screw for your shaker application by reference to the head style.

All clamps are shipped complete with hardware. Clamps for 2- to 6-liter flasks are shipped with an additional girdle to keep the flasks in place. To install 2- to 6-liter clamps:

1. Place each clamp on the platform, secure the clamp in place with the correct type and number of screws.
2. Place the loose girdle around the upper portion of clamp body so that it is held in place by the legs of the clamp.

**Figure 6: 2- to 6-Liter Clamp Installation**

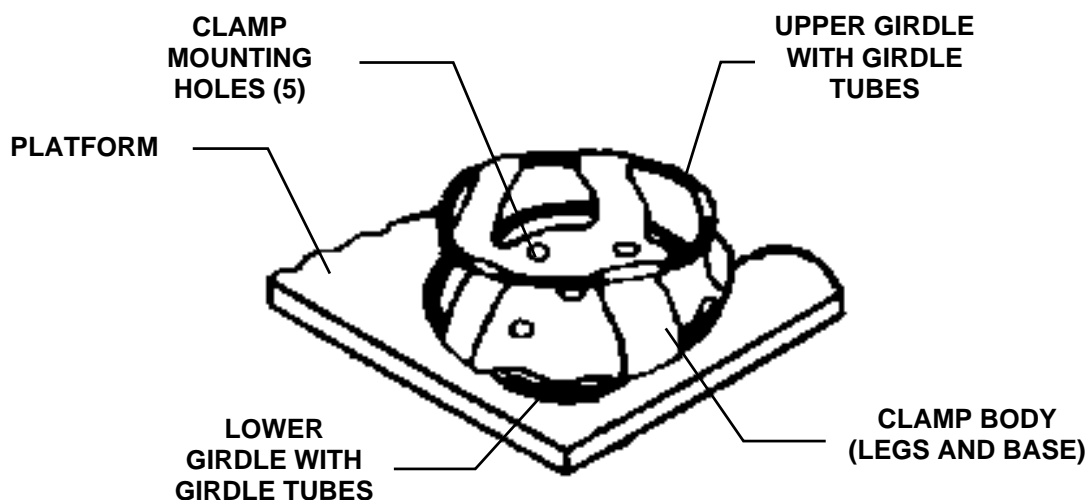

 **NOTE:**

**Also applicable to 2800 ml Fernbach Flask Clamp.**

3. Insert the flask into the clamp.

## 4 OPERATION

### 4.1 *Starting the Shaker*

To start the unit, turn the power (On/Off) switch on the back of shaker to the ON position.

The shaking action may be stopped or started by pressing the Start/Stop key.

When the shaker is running, the LED display will track the speed as it accelerates to the last entered setpoint.



#### **NOTE:**

**At higher speed ranges, we recommend that the platform have a 50% minimum load to maintain a good balance condition.**

### 4.2 *Continuous (Unlimited) Run*

1. If the LED displays “OFF”, press the Start/Stop key.
2. Press Select until RPM is lit.
3. Press either ▲ or ▼ to enter Set mode (Set indicator will light).
4. Set the speed by using the ▲ or ▼ key until the desired setpoint is displayed. Holding the ▲ or ▼ key will cause the setting to change more rapidly.

The setpoint may be changed during a run without stopping the shaker by following steps 2-4. During speed changes, the alarm may sound until the speed returns to within 5 RPM of the setpoint.

### 4.3 *Checking a Setpoint*

1. Press Select until the desired indicator is lit.
2. Press either ▲ or ▼ to enter the Set mode and display the current setpoint.



#### **CAUTION!**

**Holding the ▲ or ▼ key for more than 0.5 second causes the speed setpoint to change. Should this occur, resetting will be necessary.**

## 4.4 *Timed Functions*

The shaker may be programmed to stop automatically after a preset time period of 0.1 hour - 99.9 hours. There must be power to the shaker in order to set the timer. However, a timed run can be initiated while the unit is either shaking or stopped.

### 4.4.1 **Setting the Timer**

1. Press the Select key to light HRS.
2. Press either ▲ or ▼ to enter the Set mode, then set between 0.1 hour - 99.9 hours.
3. While Set light is lit, press the Start/Stop key. This will program the time (and start the run). The Time indicator will light and remain on for the duration of the run. At the end of the timed run, the display will read “OFF”, the Time indicator will flash, and the audible alarm will sound.
4. The setpoint may be changed during a run without stopping the shaker by following steps 1 and 2.

### 4.4.2 **Stopping the Alarm**

To stop the alarm, press the Select key and change to any other function.

### 4.4.3 **Cancelling the Timer**

To cancel the timer **without** stopping the shaker:

1. Press the Select key to light HRS.
2. Press either ▲ or ▼ to enter the Set mode, then immediately press the Start/Stop key. The Time indicator will go out and the display will read “OFF”.

## 4.5 *Alarm Functions*

Innova shakers have an audible alarm which is activated at predetermined times. It may be deactivated in the following way:

1. Press Select to light HRS.
2. **Simultaneously** press the ▲ and ▼ keys. The Set and Maint indicators will flash.

3. While the Set and Maint indicators are flashing, press the Start/Stop key. The Mute indicator will light to advise that the audible alarm is deactivated.

The alarm may be reactivated by repeating steps 1-3. The Mute indicator will be extinguished when the alarm has been reactivated.

**NOTE:**

**The shaker may be started or stopped by pressing the Start/Stop key. When starting, the unit will automatically return to the most recent function and speed setting. The audible alarm will be activated until the speed is within 5 rpm of the setpoint. The alarm will not sound, however, when the shaker is accelerating immediately after the power is turned on.**

#### **4.6 Total Running Time**

The control modules of the Innova shakers keep track of the time the shaker has been on, tracking the hours of usage.

To display the accumulated running time:

1. Select HRS using the Select key.
2. **Simultaneously** press the ▲ and ▼ keys.

The Set and Maint indicators will flash and the accumulated running time will be displayed in hundreds of hours (i.e., “02” equals 200 hours; “102” equals 10,200 hours). This display will continue for 10 seconds and then default to the previous mode readout.

After 10,000 hours of operation, the Maint indicator will light. Preventive maintenance is recommended at this point. The NBS Service Technician will deactivate the light when the technician performs the required maintenance.

*Alteration of the internal clock by unauthorized personnel will void the warranty.*

#### **4.7 Temperature/Monitor Option**

This option consists of an internal electrical interface, an RTD temperature probe and an analog output for chart recorder or computer. When this option is installed, either the ambient temperature or the temperature of any vessel on the shaker platform can be measured with the probe:

1. Remove the probe from its holder and insert it into the vessel to be monitored.

2. Use the Select key to indicate °C.

*The °C indicator will only function when the temperature/monitor option is installed.*

Since the temperature/monitor option does not provide temperature control, any attempt to enter a temperature setpoint results in the display of “Err” (Error) on the control panel.

#### 4.8 Recorder Adaptation

To record speed and temperature, a recorder (not supplied) can be used. The recorder will need to have two channels, for speed and temperature. Each channel should have signal conditioning that accepts 0-5 volt input.

A mating connector is required on the recorder cable (not supplied). This is a 9-pin male D subminiature connector, AMP Amplimite HDP-20 series or the equivalent. The pin-out diagram below identifies the application:

**Figure 7: Recorder Connector  
(as seen from the rear of the unit)**

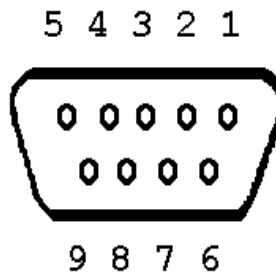

<b>Pin No.</b>	<b>Signal Name</b>	<b>Scale</b>
6	Speed	1V = 100 RPM
2	Ground	
7	Temperature	1V = 20°C
3	Ground	

## 5 MAINTENANCE

The Innova Shaker requires no routine maintenance on the part of the user, other than cleaning. At the end of 10,000 hours of use, the Maint indicator light illuminates. At that time, contact your local NBS Service Engineer or call the NBS Service Department for a maintenance visit. This periodic maintenance will keep your unit in premium condition.

**WARNING!**

**Before performing any maintenance on the unit, *always* turn the power OFF using the power switch on the rear of the shaker, and disconnect the line cord.**

### 5.1 *Cleaning*

The unit may be cleaned using a damp cloth or any standard, household or laboratory cleaner to wipe down its outer surfaces.

Do not use abrasive or corrosive compounds to clean this instrument, as they may damage the unit and void the warranty.

**THIS PAGE INTENTIONALLY BLANK**



## 6 SERVICE

The following section describes basic troubleshooting service procedures, and provides instructions to install optional features. These must be performed by a qualified service engineer.



### **WARNING!**

**Before performing any service or maintenance on the unit, *always* turn the power OFF using the power switch on the rear of the shaker, and disconnect the line cord.**

### 6.1 Replacing Fuses

To replace fuses (without changing the fusing arrangement), the service technician will follow these steps:

1. Always disconnect the unit from the power source first.
2. Using a small screwdriver, remove the cover/fuse block located on the rear of the unit. Remove the old fuse.
3. Insert a new one of the same type.
4. Replace the cover/fuse block into the power module (*see Figure 8*).

**Figure 8: Power Entry Module (2100/2150)**

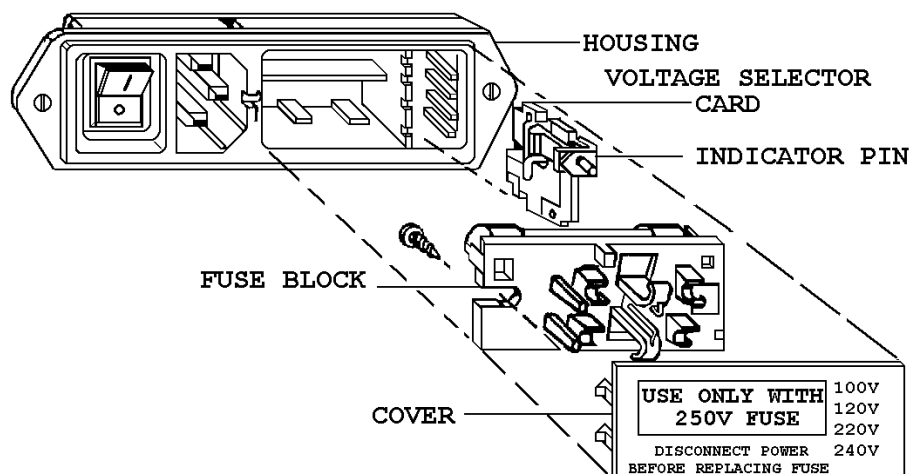

## 6.2 Changing Voltage

Innova shakers are set at the appropriate line voltage with the proper fuses prior to shipment. The power module, however, is a universal power-entry system that can be reset to adapt to worldwide power requirements. If it becomes necessary to reset the voltage on your shaker, the authorized technician will use the following procedure.

1. Disconnect the unit from the power source.
2. Open the cover of the power module, using a small blade screwdriver, and remove the cover/fuse block assembly (*see Figure 8*).
3. Remove the voltage selector card from the housing by pulling the indicator pin straight out (*see Figure 8*).
4. Along each edge of the voltage selector card, the voltage options are printed in large numbers - 100, 120, 220, 240 (*see Figure 9*). Place the card in front of you with the desired voltage printed at the bottom.
5. With the card in this position, orient the indicator pin to point up. The voltage has now been changed and the card can be reinserted.

**Figure 9: Voltage Selection**

### VOLTAGE SELECTOR CARD ORIENTATION

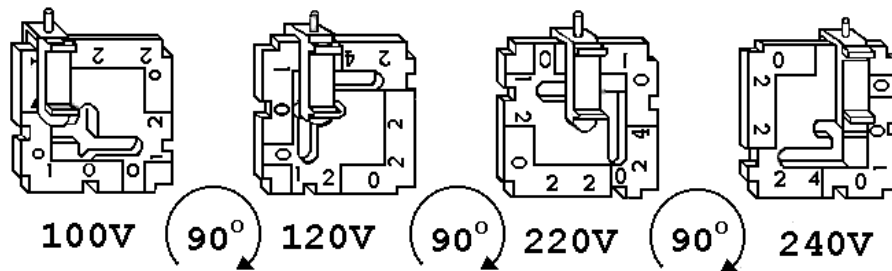

6. Hold the voltage selector card so that the indicator pin is facing you and the alignment arrow points left (*see Figure 10, on the following page*).
7. Replace the card in the voltage selector slot at the right hand end of the power module. Push it until it snaps into place.
8. Check for the correct fusing arrangement (*see Fusing, in the following section*).

### NOTE:

**Be sure the pin is facing out and the alignment arrow is pointing to the left.**

9. Reinstall the cover/fuse block assembly.
10. Verify that the indicator pin shows the desired voltage.

**Figure 10: Indicator Pin & Alignment Arrow  
(Voltage Selection)**

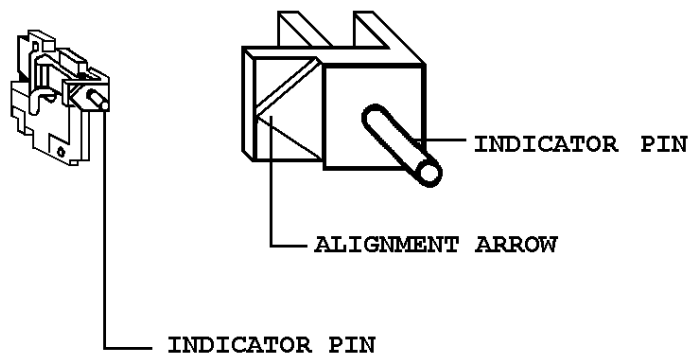

### 6.3 *Fusing*

If you change the voltage on the shaker, it may also be necessary to modify the fusing arrangement, from a single fuse to double fuses.

#### 6.3.1 **From Single to Double Fusing**

To convert from a single fuse to double fusing, the authorized service technician will:

1. Open the cover of the power module, using a small blade screwdriver, and remove the cover/fuse block assembly (*see Figure 11 on the following page*).

**Figure 11: Power Module & Fuse Block (2100/2150)**

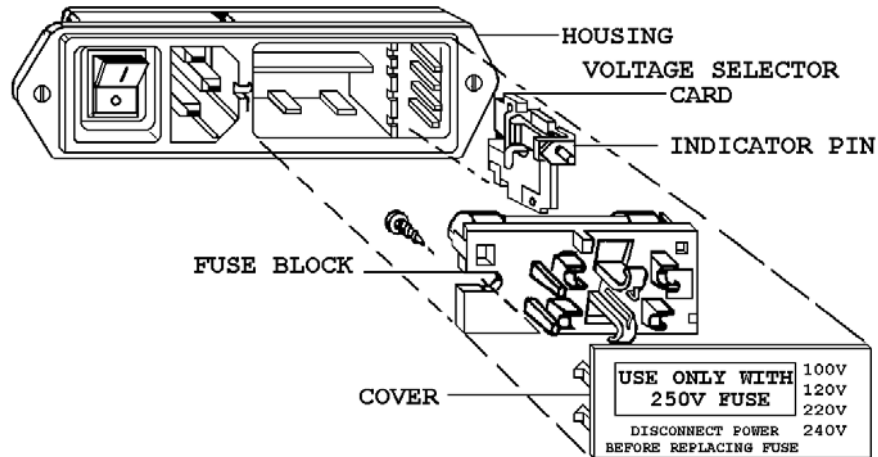

2. Loosen the Phillips head (+) screw two full turns (*see Figure 12 below*).

**Figure 12: Fuse Block/Cover Assembly (2100/2150)**

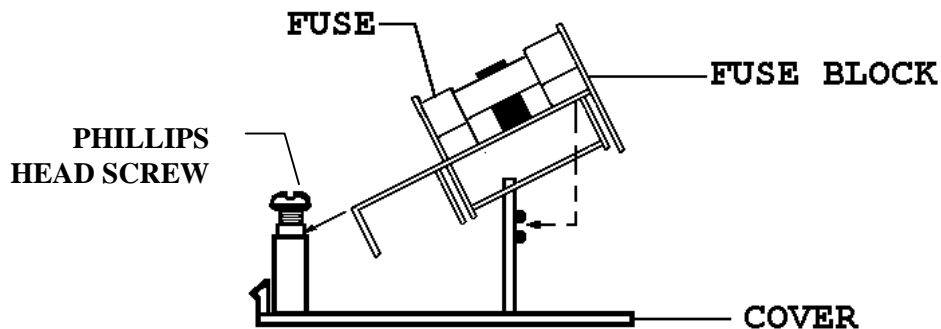

3. Remove the fuse block by sliding it up and away from the screw shaft and lifting it off the pedestal (*see Figure 12 above*).
4. Invert the fuse block, then slide it back onto the Phillips head (+) screw and pedestal. Tighten the Phillips head screw.
5. Verify the correct fusing arrangement (*see Figures 13a & 13b on the following page*).
6. Replace the cover onto the power module.

**Figure 13a: Double Fuse Arrangement**

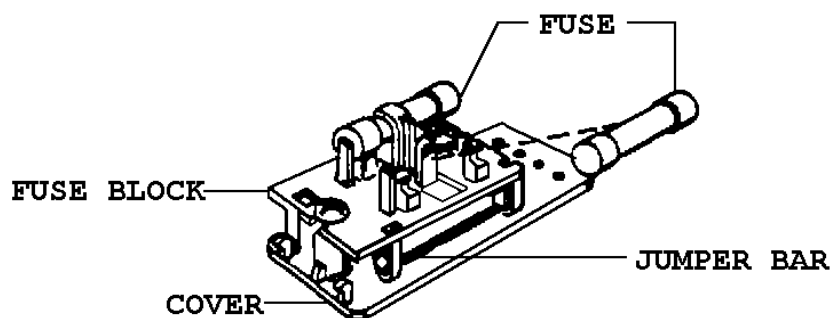

**Figure 13b: Single Fuse Arrangement**

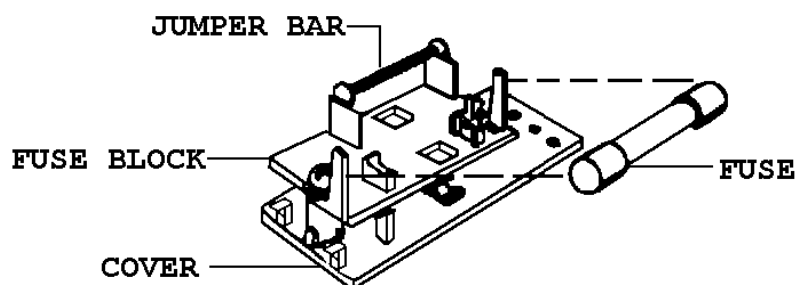

#### **6.4 Belt Replacement**

A service kit (NBS Part Number P0700-5242) is provided to aid the authorized service technician in replacing the drive belt. The kit consists of a 7½-inch x 8-inch (19cm x 20cm) Housing Extractor Plate (*Item ① in Figure 14, on the following page*) and three 3/8-16 NC x 1¼-inch long flat head Allen screws (*Item ②*). These are attached to the bottom of the shaker. To remove the kit, unscrew the three fasteners with the large Allen key provided.

All *Item* numbers in the following instructions refer to Figure 14.

1. Thread the three 1¼-inch long screws (*Item ②*) into the three threaded holes in the extractor plate until they are flush to the back of the plate.
2. Remove the platform from the Innova shaker by unscrewing the four ¼-inch flat head screws (*Item ⑤*).

3. Using the small Allen key, remove the three  $\frac{1}{4}$ -20 x  $\frac{1}{2}$ -inch long flat head Allen screws (*Item ③*) that hold the bearings in place on the upper housing. Also remove the three countersunk washers (*Item ④*).
4. Orient the plate on the upper bearing housing so that the three  $\frac{3}{8}$ -inch screws (*Item ②*) sit in the center of the three bearings.

**Figure 14: Upper Bearing Housing & Extractor Plate Detail (2100/2150)**

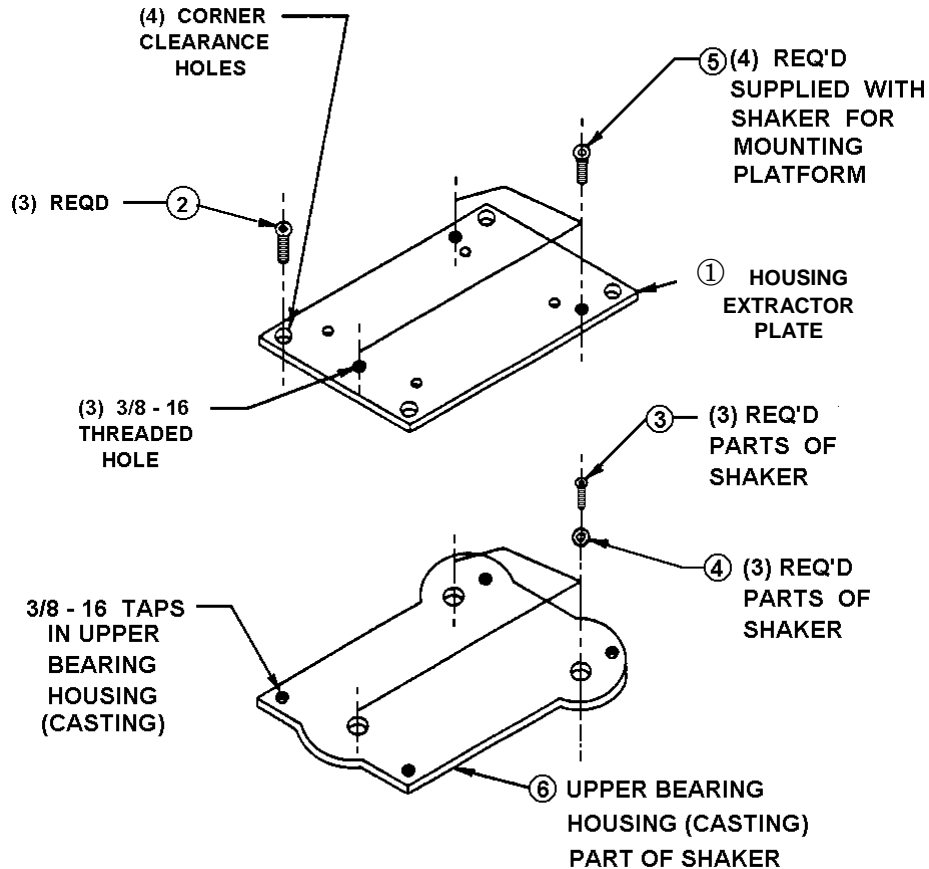

5. Use the large Allen key provided to mount the plate to the upper housing, utilizing the four platform screws (*Item ⑤*) set aside in Step 2. Tighten the four screws securely (*see Figure 15 on the following page*).
6. Using the larger Allen key on the three  $\frac{3}{8}$ -inch screws (*Item ②*), turn each screw one half turn in sequence until the upper bearing housing is lifted free of the eccentric shafts. Remove the four platform screws (*Item ⑤*), thus disconnecting the plate from the upper bearing housing (*see Figure 15*).

**Figure 15: Bearing Housing Assemblies (2100/2150)  
(with extractor plate in place)**

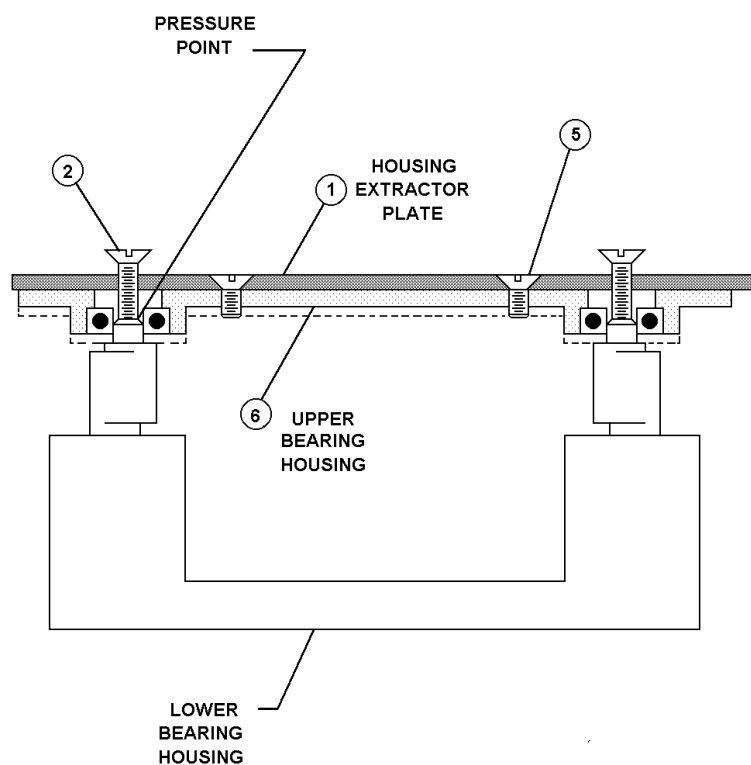

7. Remove the old belt by rotating the pulley slowly and feeding the belt out with a slight upward pressure on the belt.
8. Install a new belt: slip the new belt over the main eccentric shaft, which is the shaft with the counterweight.
9. Position the three eccentric shafts so that they all face the same direction (*see Figure 16 on the following page*).
10. Using a soft mallet or the back end of a wooden hammer handle, lightly tap the upper housing near the three bearings until there is even engagement of the bearings onto the shafts. **NEVER TAP THE CASTING WITH METAL.**

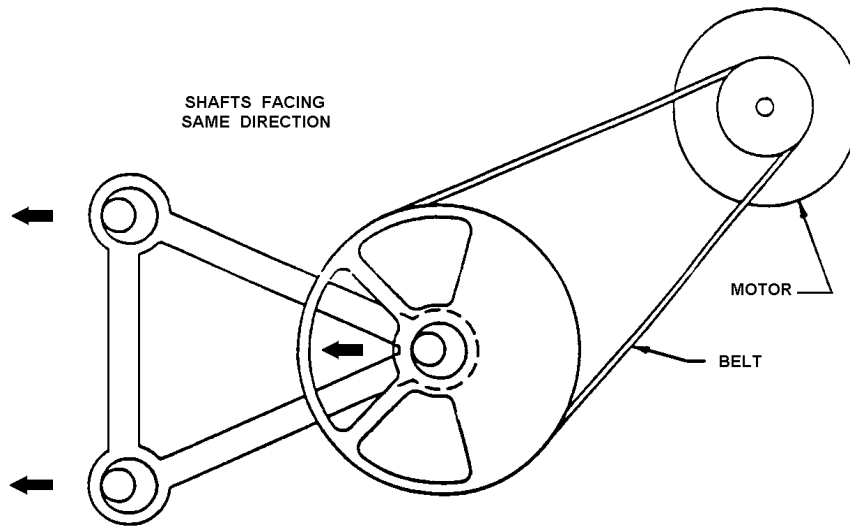
**Figure 16: Eccentric Shafts & Pulley**

11. Place the three washers (*Item ④ in Figure 14*) set aside in Step 3, with countersink face up, onto each of the bearings.
12. Reinstall the three  $\frac{1}{4}$ -20 x  $\frac{1}{2}$ -inch long flat head screws (*Item ③ in Figure 14*) through the washers and engage the eccentric shaft threads. Tighten evenly in sequence and be sure each bearing is fully seated on the shaft.
13. Guide the belt onto the two pulley grooves. Check the belt adjustment by applying finger pressure to the belt midway between the two pulleys. The belt should deflect approximately  $\frac{3}{8}$  inch (9.5 mm). *If the belt requires further adjustment, see Belt Adjustment, the following section.*
14. Replace the platform. The machine is ready for operation

#### 6.4.1 Belt Adjustment

If the belt does not deflect approximately  $\frac{3}{8}$  inch (9.5 mm), an adjustment is required:

1. Loosen the two hex nuts on the motor assembly (*see Figure 17 on the following page*).



**Figure 17: Motor/Mounting Plate Assembly (2100/2150)**

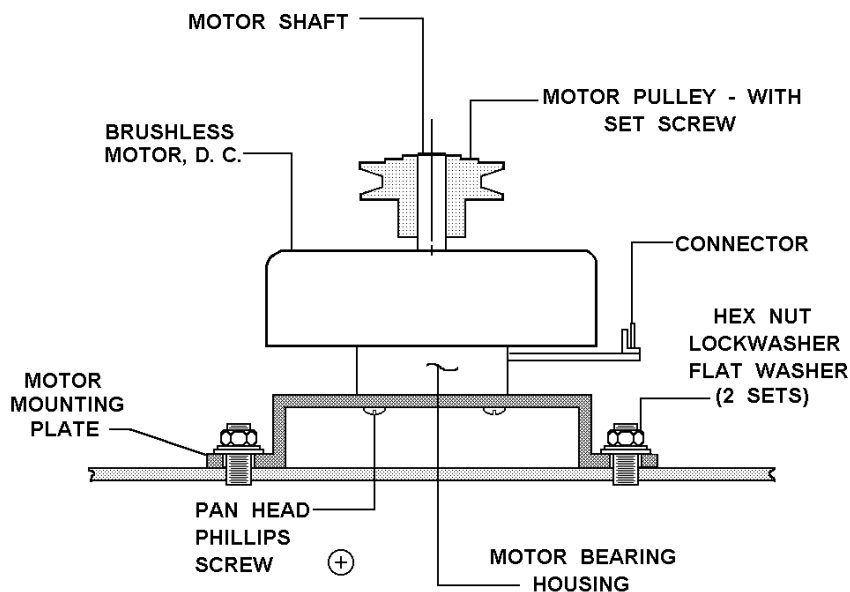

2. Move the motor assembly until the belt is tight.
3. Tighten the hex nuts and recheck the belt tension by exerting pressure on the belt. The belt should deflect approximately  $\frac{3}{8}$  inch (9.5 mm).
4. Replace the platform. The machine is ready for operation.

## 6.5 Motor Assembly Replacement

If the motor assembly needs to be replaced, the authorized service technician will:

1. Remove the platform.
2. From the deck, remove the two hex nuts and washers that retain the motor mounting plate (*see Figure 17, repeated on the following page*).
3. Remove the belt and carefully disconnect the harness connector from the motor assembly.
4. Loosen the set screw that holds the motor pulley in place and remove the pulley (*see Figure 17*).

**Figure 17: Motor/Mounting Plate Assembly (2100/2150)**

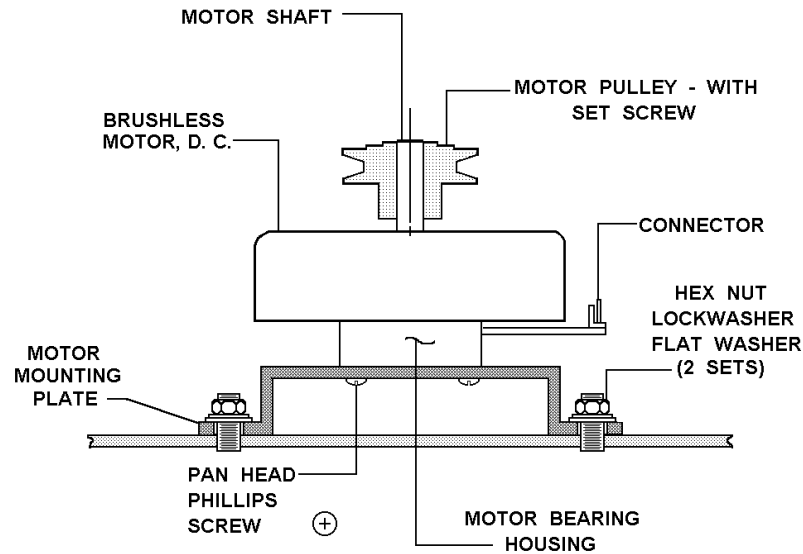

5. Remove the three 10-32 screws and lock washers that retain the motor bearing housing to the motor mounting plate. *Note the orientation of the electrical connector.*
6. Remove the motor assembly.
7. Mount the new motor assembly onto the motor mounting plate with the connector oriented as noted in Step 5 above. Tighten the three 10-32 screws with the lock washers in place.
8. Replace the motor pulley. Finger tighten the set screw, making sure the set screw is on the flat of the shaft.
9. Mount the assembly on the deck using the hex nuts and washers removed in Step 2 (*see Figure 17*). Tighten the hex nuts just until they come into contact with the deck.
10. Connect the harness connector to the motor assembly with the orientation noted in Step 5. The left side of the connector (as you face the motor) **must** be flush with the motor connector, and the blank pin **must** be visible on the right side (*see Figure 18 on the following page*). Also, ensure the cable is routed so it clears all moving parts.
11. Guide the belt into the pulley grooves. Adjust the height of the motor pulley so that the belt is parallel to the base (use a straight edge across the pulleys). Tighten the set screw in the motor pulley.
12. Adjust the belt tension so that there is approximately a  $\frac{3}{8}$  inch (9.5 mm) deflection in the belt. (*See Belt Replacement procedure for adjustments.*)

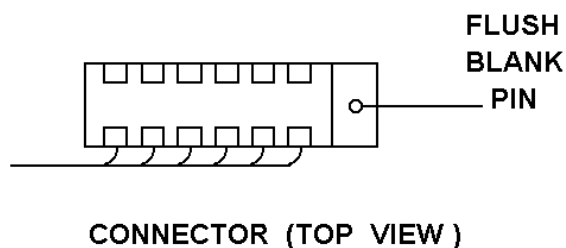
**Figure 18: Proper Harness Connection**

## 6.6 Temperature/Monitor Option

The temperature/monitor option package (NBS part number M1194-9924) is available for both Innova 2100 and 2150 model shakers, to provide the following features:

- Digital Temperature Readout: to monitor the ambient temperature or the temperature of the liquid in any vessel with an RTD-based electronic device. The value is displayed on the LED readout on the control panel when the option is installed.
- Remote Monitoring: 0-5V analog recorder output for both temperature and speed. Can be used with an external chart recorder or a computer that has a data acquisition card.

When the authorized service technician performs the retrofit installation of this option, he will first determine that the following parts are included in the kit:

<b>Quantity</b>	<b>Description</b>	<b>NBS Part No.</b>
1	Installation instructions	TM1194-9924
1	Temperature Monitor PC Board	M1192-7000
1	RTD Temperature Sensor Assembly	M1194-8000
1	RTD & Recorder Cable Assembly.	M1191-8020
1	Bracket Assembly	M1194-5000
1 Mounting Hardware Kit, consisting of the following:		
3	Hex spacers 6/32 inch x ½ inch	P0160-2273
3	6-32 x ¼ inch Pan head Phillips screws	
2	6-32 x 5/16 inch Pan head screws	
2	6-32 x ½ inch Pan head screws	
1	Jack screw kit	P0100-7641
3	Nylon washers	P0100-9090
2	#6 flat washers	
4	#6 lock washers	
2	6/32 hex nuts	
2	Cable clamps	EC-157

The authorized technician will follow these steps to install the kit :

1. Stop the shaker with the Start/Stop key (if necessary).
2. Turn the unit Off using the power switch on the shaker's rear panel, and remove the line cord.
3. Remove the shaker platform.
4. Remove the five screws that hold the front panel, allowing the front panel to lay on its face (*see Figure 19*).
5. Remove the three nuts and three washers from positions A, B and C on the main control board (*see Figure 19*).

**Figure 19: Front Panel Assembly (2100/2150)**

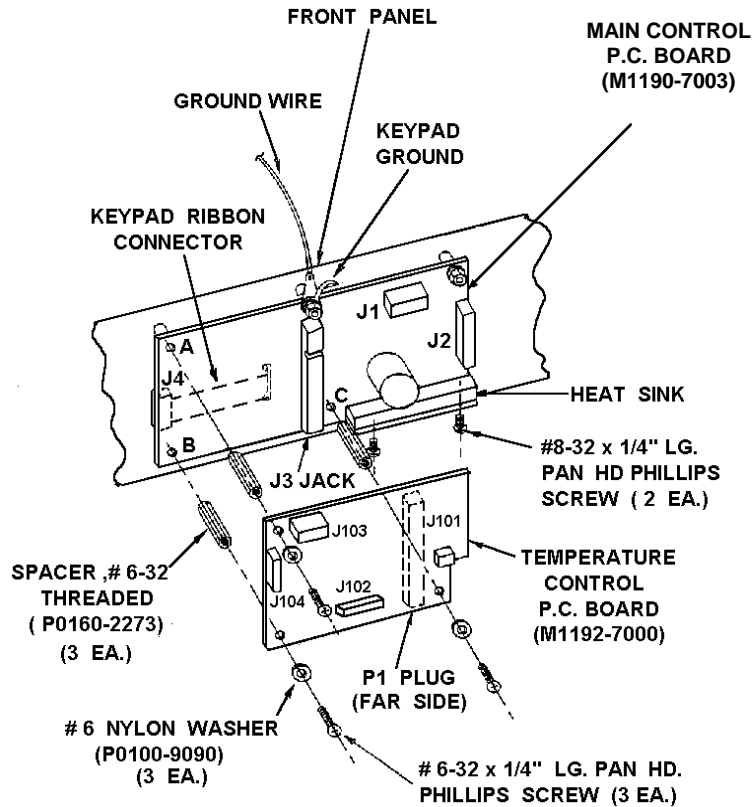

6. Screw on the three hex spacers (P0160-2273) in positions A, B and C (*see Figure 19 above*).
7. Align the mating connector on the temperature module PC board with the option connector on the main control board and press down until the connector is seated (*see Figure 19*).
8. Secure the temperature module to the main control board with the three 1/4-inch screws and nylon washers provided.

9. Remove the cover plate at the rear of the shaker (*see Figure 2*). Retain the mounting hardware.
10. Mount the RTD (round connector) with the hardware used to hold the cover plate.
11. Mount the chart recorder connectors with the hardware provided in the jack screw kit (P0100-7641).
12. Carefully route both cables along the lower right side of the shaker and secure with the cable clamps and ½-inch long screws provided.
13. Connect the 4-pin connector coming from the chassis harness assembly to J101, cutting the plastic strap (*see Figure 19*).
14. Connect the RTD cable's 6-pin connector to J103 on the temperature control module (*see Figure 19*).
15. Connect the chart recorder cable's 10-pin connector to J104 on the temperature control module (*see Figure 19*).
16. Carefully put the front panel back in place and secure with screws.

**CAUTION!**

**Before tightening the screws, make sure that no wires are pinched between the front panel and the shaker chassis.**

17. Place the unit on its side. Mount the RTD bracket assembly (M1194-5000) and the ½-inch pan head screws provided.
18. Place unit in its normal operating position, and reinstall the platform.
19. Connect line cord to the back of unit.

*See Features Section 2.5.1 and Operation Sections 4.7 and 4.8 for details on the temperature monitor and chart recorder functions.*

## 6.7 Replacing Electronic Boards

**WARNING!**

**The following procedure is to be performed ONLY by an authorized Service Technician.**

**WARNING!**

**Integrated circuits are extremely susceptible to damage from electrostatic discharge (ESD). Read and follow the precautions in the following section before proceeding.**

### 6.7.1 ESD Precautions

1. Do not remove components from their antistatic packaging until you are ready to insert them into their sockets or install the board.

2. Wear a wrist grounding strap, available from most electronic component stores.
3. Before handling components or boards, touch an unpainted portion of the system unit chassis for a few seconds.

## 6.8 Capacity Upgrade Option

This kit (NBS part number M1194-9926) allows an Innova 2100 (which has an 18-inch x 18-inch/46cm x 46 cm platform) to be converted to an Innova 2150 (with a 18-inch x 24-inch/46cm x 61 cm platform).

Prior to installing the kit, the authorized technician will determine that all parts are present in the package:

<b>Quantity</b>	<b>Description</b>	<b>NBS Part No.</b>
1	Counterweight (with tapped holes)	M1194-9301
2	Counterweight	M1194-9302
2	1/4-20 x 1 3/4-inch long Phillips pan head screws	
2	Lock washers	
4	Outriggers (one each left front, right front, left rear and right rear)	
8	1/4-20 x 3/4-inch long Phillips pan head screws	

To install the kit, the authorized technician will follow these steps:

1. Turn off the power switch to the Off position and remove the power cord.
2. Remove the platform from the upper housing (if one is in place).
3. Rotate the pulley so that the heavy section is in the extreme right position (*see Figure 20 on the following page*).
4. Slip the counterweights under the pulley: mount both M1194-9302 counterweights first, then the M1194-9301 counterweights, then the one M1191-9312 counterweight with tapped holes (*see Figure 20*). Attach them with two 1/4-20 x 1 3/4-inch long screws and their lock washers. Make sure each lock washer is under the screw head and the screws are securely tightened.
5. Reinstall the platform.
6. Plug in the power cord and switch on the power. The shaker is ready for operation.

**Figure 20: Counterweight & Pulley Assembly**

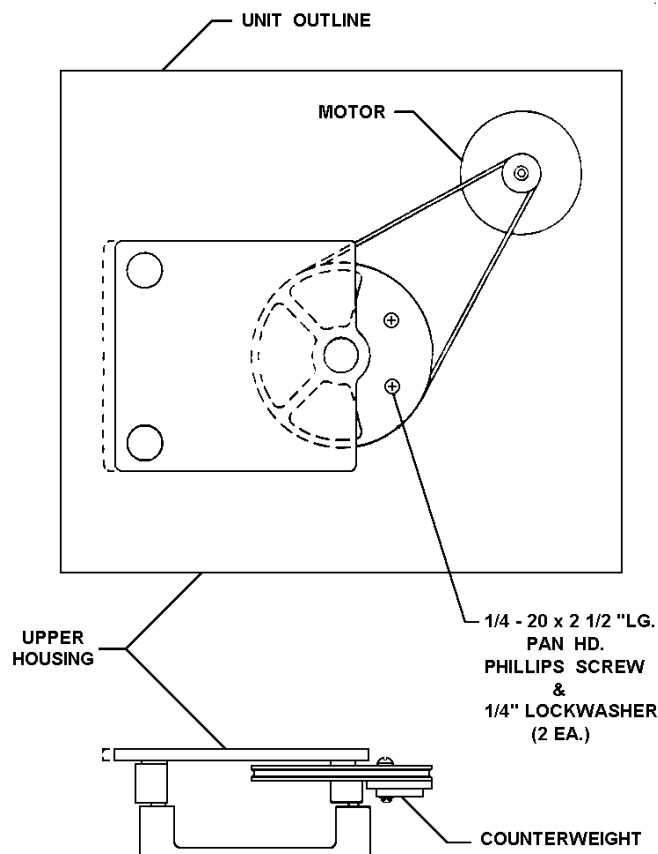

### 6.8.1 Outrigger Kit

High loads and speeds require the extra stability provided by the Outrigger kit (the components of which are included with the capacity upgrade kit).

To mount the outriggers, the authorized technician will:

1. Lay a soft cloth or cardboard adjacent to the unit, then set the unit on its side, being careful to protect the finish of the shaker.
2. Remove all the rubber feet by unscrewing the screw in the middle of each foot. These will no longer be needed for the outrigger addition.
3. Mount the four outriggers with the eight 1/4-inch x 3/4-inch long screws. Take care to mount each plate *as shown in Figure 21 on the following page*, and to adjust so that there is sufficient clearance to remove the front control panel for servicing.

**Figure 21: Outrigger Feet (2100/2150)**

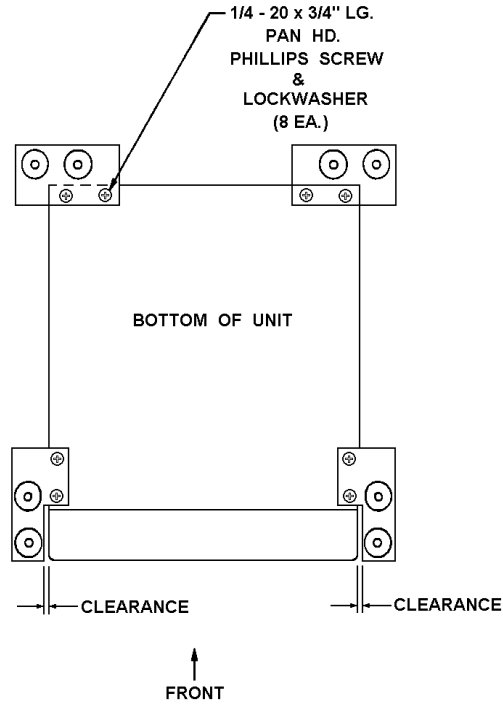

### 6.9 Quick Change Platform Option (Innova 2100)

The easy-loading Quick Change Platform kit (NBS part number M1192-9901) enables users of the Innova 2100 (**without** Capacity Upgrade) to change or mount the series of 18-inch x 18-inch (46 cm x 46 cm) platforms without the use of tools or hardware.

*When this kit is installed, the maximum speed should be limited to 400 RPM.*

Prior to installing the kit, the authorized technician will determine that all parts are present in the package:

<b>Quantity</b>	<b>Description</b>
1	Plastic Subplatform with springs, retainers and friction pads attached
1	Counterweight with tapped holes
2	1/4-20 x 1 1/2-inch long pan head Phillips screws
2	Lock washers
4	1/4-20 x 3/4-inch long Allen socket flat head screws
1	Allen key wrench



To install the kit, the authorized technician will follow these steps:

1. Turn the power off using the power switch and disconnect the line cord.
2. Remove the existing platform, if one is on the machine.
3. Rotate the pulley so that the heavy section is in the extreme right position (*see Figure 20, repeated below*).

**Figure 20: Counterweight & Pulley Assembly**

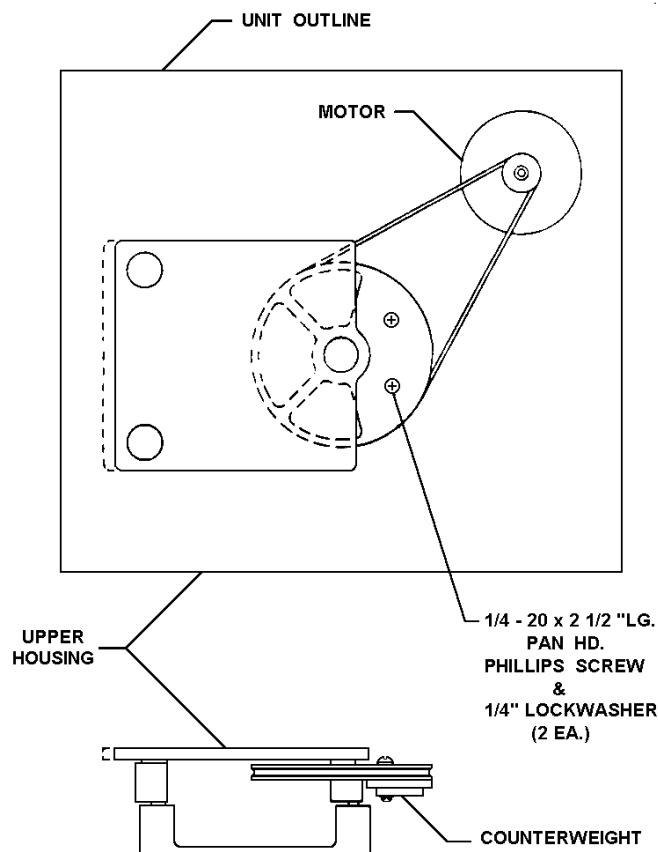

4. Slip the counterweight under the pulley, mounting it with the two 1/4-20 x 1½-inch long screws and lock washers supplied. Make sure the lock washer is under the screw head and the screws are securely tightened.
5. Mount the subplatform with the four flat head screws, keeping the side with the two springs to the front of the machine. Tighten the screws securely.
6. Slip any 18-inch x 18-inch (46 cm x 46 cm) platform between the side guides, push the platform to the rear retainer and press down on the front edge of the platform. It should snap down into place and be retained by the springs.
7. Check that the rear edge of the platform is engaged under the bend of the rear clip.
8. Plug in the power cord, switch on the power and the unit is ready for operation.

### 6.9.1 Removing the Quick Change Platform

To remove the Quick Change platform:

1. Stop the machine by pressing the Start/Stop key.
2. Face the machine squarely.
3. Put your index fingers under each front corner of the platform. Note that there is a relief in these corners on the subplatform.
4. With your thumbs, press the two corner springs toward your body, and with an upward pressure with your index fingers, lift the platform from its retained position.

### 6.10 Quick Change Platform Option (Innova 2150)

The easy-loading Quick Change Platform kit (NBS part number M1194-9927) enables users of the Innova 2150 to change or mount the series of 18-inch x 24-inch (46 cm x 61 cm) platforms without the use of tools or hardware.

*When this kit is installed, the maximum speed should be limited to 400 RPM.*

Prior to installing the kit, the authorized technician will determine that all parts are present in the package:

<b>Quantity</b>	<b>Description</b>
1	Plastic Subplatform with springs, retainers and friction pads attached
1	Counterweight with clearance holes
2	1/4-20 x 1 3/4-inch long pan head Phillips screws
2	Lock washers
4	1/4-20 x 3/4-inch long Allen socket flat head screws
1	Allen key wrench

To install the kit, the authorized technician will follow these steps:

1. Turn the power off using the power switch and disconnect the line cord.
2. Remove the existing platform, if one is on the machine.
3. Rotate the pulley so that the heavy section is in the extreme right position (*see Figure 20, repeated below for convenience*).
4. Slip the counterweight under the pulley, mounting it with the two 1/4-20 x 1 3/4-inch long screws and lock washers supplied. Make sure the lock washer is under the screw head and the screws are securely tightened.

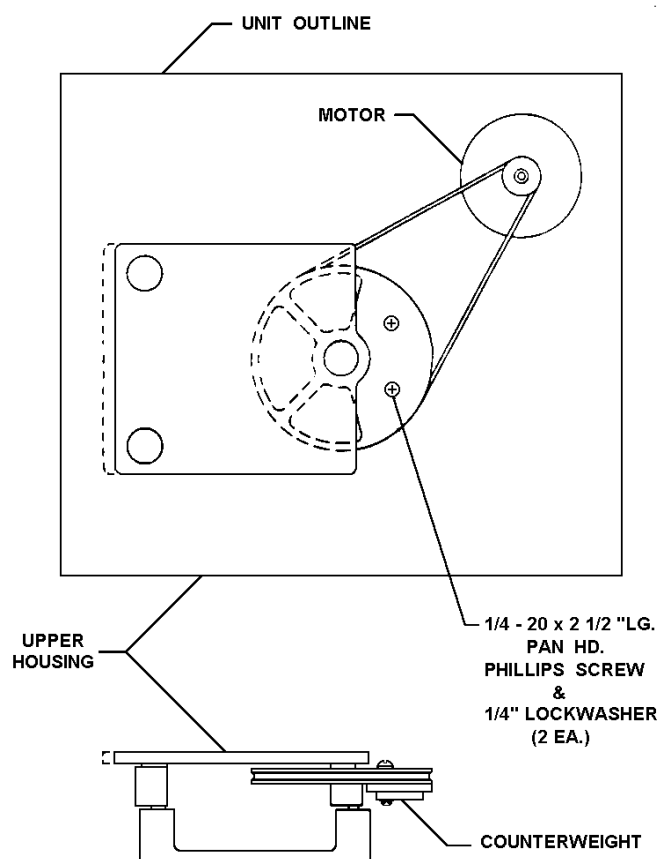
**Figure 20: Counterweight & Pulley Assembly**

5. Mount the subplatform with the four flat head screws, keeping the side with the two springs to the front of the machine. Tighten the screws securely.
6. Slip any 18-inch x 24-inch (46 cm x 61 cm) platform between the side guides, push the platform to the rear retainer and press down on the front edge of the platform. It should snap down into place and be retained by the springs.
7. Check that the rear edge of the platform is engaged under the bend of the rear clip.
8. Plug in the power cord, switch on the power and the unit is ready for operation.

### 6.10.1 Removing the Quick Change Platform

To remove the Quick Change platform:

1. Stop the machine by pressing the Start/Stop key.
2. Face the machine squarely.
3. Put your index fingers under each front corner of the platform. Note that there is a relief in these corners on the subplatform.
4. With your thumbs, press the two corner springs toward your body, and with an upward pressure with your index fingers, lift the platform from its retained position.

### **6.11      *MAINT Indicator***

After 10,000 hours accumulated shaker running time, the Maint indicator light on the control panel will light. Only an NBS Service Engineer can turn it off.

The Maint light indicates that a routine maintenance check is recommended. Call NBS Service to schedule an appointment.

A regular schedule of routine maintenance is an excellent way to keep your valuable equipment performing optimally for years of reliable service.

# 7 PARTS & ACCESSORIES

## 7.1 Service Parts (2100/2150)

<b>NBS Part No.</b>	<b>Description</b>	<b>Quantity</b>
P0380-3710	0.16A 5x20 mm Fuse	1
P0380-3530	1.6A 3AG Fuse	1
P0420-1610	10VA Transformer	1
M1191-5300	130VA Transformer Assembly	1
P0320-0350	2100 $\mu$ F Capacitor	1
P0460-4091	Diode Bridge	1
P0360-4040	130V Varistor	2
M1195-4001	Medium Motor Assembly	1
M1190-9940	Main Control P.C.B. Assembly	1
M1190-5000	Membrane Switch Panel	1
P0460-2200	Power Entry Module	1
P0720-2053	Power Cord 120V 10A	1
P0720-2021	Power Cord 220V	1
P0180-0102	Bearing, Sealed, Upper	3
P0180-0101	Bearing Shield, Lower	6
P0700-5242	Belt	1
M1194-6330	Bearing Housing Assembly	1
M1194-8000	Stainless Steel RTD Assembly (Optional)	1
M1194-0050	Innova 2100/2150 Operations Manual	1

## 7.2 Innova 2100 Interchangeable Platforms

<b>Catalog Number</b>	<b>18 x 18-inch (46 x 46cm) Platform Size*</b>	
	<b>Clamp Quantity</b>	<b>Size of Glassware</b>
M1194-9909	Utility Carrier	
M1194-9910	Utility Tray	
M1194-9902	Universal Platform	
M1194-9903	64	50mL Erlenmeyer Flask
M1194-9904	34	125mL Erlenmeyer Flask
M1194-9905	25	250/300mL Erlenmeyer Flask
M1194-9906	16	500mL Erlenmeyer Flask
M1194-9907	9	1L Erlenmeyer Flask
M1194-9908	5	2L Erlenmeyer Flask

\*All above platforms constructed of phenolic composite

### 7.3 *Innova 2150 Interchangeable Platforms*

Catalog Number	18 x 24-inch (46 x 61cm) Platform Size*	
	Clamp Quantity	Size of Glassware
M1194-9921	Utility Carrier	
M1194-9922	Utility Tray	
M1194-9912	Universal Platform	
M1194-9915	80	50mL Erlenmeyer Flask
M1194-9916	48	125mL Erlenmeyer Flask
M1194-9917	35	250/300mL Erlenmeyer Flask
M1194-9918	20	500mL Erlenmeyer Flask
M1194-9919	12	1L Erlenmeyer Flask
M1194-9920	8	2L Erlenmeyer Flask

\*All above platforms constructed of phenolic composite

### 7.4 *Accessory Flask Clamps*







NBS Catalog No.	Clamp Type
ACE-105	10mL Erlenmeyer Clamp
ACE-255	25mL Erlenmeyer Clamp
ACE-505	50mL Erlenmeyer Clamp
ACE-125S	125mL Erlenmeyer Clamp
ACE-250S	250mL Erlenmeyer Clamp
ACE-500S	500mL Erlenmeyer Clamp
ACE-1000S	1.0L Erlenmeyer Clamp
ACE-2000S	2.0L Erlenmeyer Clamp
ACE-4000S	4.0L Erlenmeyer Clamp
ACE-6000S	6.0L Erlenmeyer Clamp
ACFE-2800S	2800mL Fernbach Flask Clamp
ACSB-500S	500mL Media Bottle Clamp
ACSB-1000S	1.0L Media Bottle Clamp

All of the above clamps are stainless steel.







### 7.5 *Clamp Mounting Hardware Kit*

NBS Flask Clamps are used on a variety of shaker platforms. Flat head screws of different lengths and thread pitch are used to secure the clamp. The following tables identify the proper screw for your shaker application by reference to the head style.

### 7.5.1 Hardware for 10 mL to 500 mL Clamps

<i>Description</i>	<i>Part Number</i>	<i>Qty.</i>	<i>Application</i>
 10-24 x 5/8 (15.87 mm) flat Phillips (+) head screw	S2116-3101	1	3/4" (19.05 mm) thick wood platform 
 10-24 x 5/16 (7.9 mm) flat Phillips (+) head screw	S2116-3051	1	5/16" (7.9 mm) thick aluminum, phenolic and stainless steel platforms. 
 10-32 x 5/16 (7.9 mm) flat slotted (-) head screw	S2117-3050	1	all stainless steel platforms 

### 7.5.2 Hardware for 1-Liter to 6-Liter Clamps

<i>Description</i>	<i>Part Number</i>	<i>Qty.</i>	<i>Application</i>
 10-24 x 5/8 (15.87 mm) flat Phillips (+) head screw	S2116-3101	5	3/4" (19.05 mm) thick wood platform 
 10-24 x 5/16 (7.9 mm) flat Phillips (+) head screw	S2116-3051	5	5/16" (7.9 mm) thick aluminum, phenolic and stainless steel platforms. 
 10-32 x 5/16 (7.9 mm) flat slotted (-) head screw	S2117-3050	5	all stainless steel platforms 

#### **NOTE:**

The above chart also applies to 2800 mL Fernbach Flask Clamps.

## 7.6 Optional Kits

### 7.6.1 Temperature/Monitor Option

The temperature and speed monitoring kit (NBS part number M1194-9924) allows an Innova 2100 or 2150 to measure and display sample or ambient temperature and to record it on a remote chart recorder or computer. This kit consists of an internal electrical interface, an RTD temperature probe and an analog output for chart recorder or computer. **The package does not include a chart recorder.**

This kit must be installed by an authorized service technician.

### 7.6.2 Quick Change Platform Kit

The easy-loading Quick Change Platform enables users of the Innova 2100 or Innova 2150 to snap in or out any platform of an appropriate size, without the use of tools or hardware.

This kit should be installed by an authorized service technician.

<b>Quick Change Platform Kit</b>		
Innova 2100	Kit #M1192-9901	18 x 18-inch (46 x 46cm) platforms
Innova 2150	Kit #M1194-9927	18 x 24-inch (46 x 61cm) platforms

### 7.6.3 Capacity Upgrade Option

With this kit (NBS part number M1194-9926), an Innova 2100, which has an 18-inch x 18-inch (46cm x 46 cm) platform, can be converted to an Innova 2150, with an 18-inch x 24-inch (46cm x 61cm) platform.

The kit consists of counterweighting, hardware, and outrigger feet. Platforms must be purchased separately.

This option must be installed by a qualified service engineer.



## 8 SPECIFICATIONS

*This chapter provides technical details of interest, but not necessarily essential for operation of the instrument.*

<b>INNOVA 2100</b>	
<b>SHAKING</b>	
<b>Speed</b>	25-500 RPM
<b>Motion</b>	¾ inch (19 mm) diameter circular orbit
<b>Indication</b>	LED digital electric display, 1 RPM increments
<b>Setpoint &amp; Control</b>	Digital adjustment with PI microprocessor control and instantaneous visual feedback
<b>Accuracy</b>	± 1 RPM (see <b>NOTE</b> at bottom of page)
<b>DRIVE</b>	
Triple eccentric counterbalanced ball bearing drive.	
<b>TIMER</b>	
<ul style="list-style-type: none"> <li>• Programmable shaking periods from 0.1 hour to 99.9 hours by a digital timer that shuts off at the end of period and energizes status light.</li> <li>• Timer counts down and digital display indicates remaining time. Can be deactivated for continuous operation.</li> <li>• Additionally, unit will display total accumulated running time for service information.</li> </ul>	
<b>AMBIENT OPERATING ENVIRONMENT</b>	
0° - 60°C, 90% humidity, non-condensing	
<b>SELF-DIAGNOSTIC STATUS</b>	
Warning signal (audible and visible) indicates when shaking speed deviates more than 5 RPM and when timer operation has expired. The audible alarm can be deactivated/activated by the operator.	
<b>REMOTE SPEED MONITORING (optional)</b>	
<ul style="list-style-type: none"> <li>• Chart recorder output for speed 0.5V, 1V per 100 RPM.</li> <li>• Accuracy ± 25mV.</li> </ul>	
<b>TEMPERATURE MONITORING (optional)</b>	
<ul style="list-style-type: none"> <li>• RTD digital temperature monitor displays individual flask or ambient temperature in 0.1°C increments.</li> <li>• Chart recorder output provided.</li> </ul>	
<b>AUTOMATIC RESTART</b>	
<ul style="list-style-type: none"> <li>• Unit will automatically restart after undesired power interruption.</li> <li>• Setpoints are maintained by non-volatile memory.</li> <li>• Interruption is indicated by a flashing LED display.</li> </ul>	



### **NOTE:**

**At 25-400 RPM, the unit will perform to specifications with up to ±10% line voltage fluctuation. To attain speed accuracy at 401-500, the line voltage cannot be lower than 5% of the rated voltage.**

<b>MOTOR</b>		
1/15 HP, 3-phase brushless ball bearing DC motor.		
<b>ELECTRICAL SERVICE</b>		
<ul style="list-style-type: none"> <li>• 100V, 120V, 220V, 240V</li> <li>• All voltages 50/60 Hz, 80VA.</li> <li>• Universal power entry system adapts to U.S. or international requirements.</li> </ul>		
<b>ELECTRICAL PROTECTION</b>		
<ul style="list-style-type: none"> <li>• Main fuse(s) in power entry module.</li> <li>• Control circuits provided with separate fuse.</li> </ul>		
<b>DIMENSIONS</b>		
<b>Width</b>	19 inches	48 cm
<b>Depth</b>	21 $\frac{7}{8}$ inches	55.5 cm
<b>Height</b> (to platform surface)	6 $\frac{3}{8}$ inches	17 cm
<b>PLATFORM DIMENSIONS</b>		
	18 inches x 18 inches	46 cm x 46 cm
<b>CONSTRUCTION</b>		
<ul style="list-style-type: none"> <li>• Heavy gauge steel, phosphate-coated and texture-painted cabinet.</li> </ul>		
<b>WEIGHT</b>		
<b>Net</b>	76 lbs	34.5 kg
<b>Gross</b>	120 lbs	54.5 kg

**NOTE:**

The Innova 2100 shaker can be upgraded to a larger capacity platform with a kit that converts this shaker to an Innova 2150. This kit can be installed in the field (*see Section 7.6.3, Capacity Upgrade Option*).

<b>INNOVA 2150</b>	
<b>SHAKING</b>	
<b>Speed</b>	25-500 RPM
<b>Motion</b>	$\frac{3}{4}$ inch (19 mm) diameter circular orbit
<b>Indication</b>	LED digital electric display, 1 RPM increments
<b>Setpoint &amp; Control</b>	Digital adjustment with PI microprocessor control and instantaneous visual feedback
<b>Accuracy</b>	$\pm 1$ RPM (see <b>NOTE</b> at bottom of page)
<b>DRIVE</b>	
Triple eccentric counterbalanced ball bearing drive.	
<b>TIMER</b>	
<ul style="list-style-type: none"> <li>• Programmable shaking periods from 0.1 hour to 99.9 hours by a digital timer that shuts off at the end of period and energizes status light.</li> <li>• Timer counts down and digital display indicates remaining time. Can be deactivated for continuous operation.</li> <li>• Additionally, unit will display total accumulated running time for service information.</li> </ul>	
<b>AMBIENT OPERATING ENVIRONMENT</b>	
0° - 60°C, 90% humidity, non-condensing	
<b>SELF-DIAGNOSTIC STATUS</b>	
Warning signal (audible and visible) indicates when shaking speed deviates more than 5 RPM and when timer operation has expired. The audible alarm can be deactivated/activated by the operator.	
<b>REMOTE SPEED MONITORING (optional)</b>	
<ul style="list-style-type: none"> <li>• Chart recorder output for speed 0.5V, 1V per 100 RPM.</li> <li>• Accuracy <math>\pm 25</math>mV.</li> </ul>	
<b>TEMPERATURE MONITORING (optional)</b>	
<ul style="list-style-type: none"> <li>• RTD digital temperature monitor displays individual flask or ambient temperature in 0.1°C increments.</li> <li>• Chart recorder output provided.</li> </ul>	
<b>AUTOMATIC RESTART</b>	
<ul style="list-style-type: none"> <li>• Unit will automatically restart after undesired power interruption.</li> <li>• Setpoints are maintained by non-volatile memory.</li> <li>• Interruption is indicated by a flashing LED display.</li> </ul>	
<b>MOTOR</b>	
1/15 HP, 3-phase brushless ball bearing DC motor.	
<b>ELECTRICAL SERVICE</b>	
<ul style="list-style-type: none"> <li>• 100V, 120V, 220V, 240V</li> <li>• All voltages 50/60 Hz, 80VA.</li> <li>• Universal power entry system adapts to U.S. or international requirements.</li> </ul>	

**NOTE:**

**At 25-400 RPM, the unit will perform to specifications with up to  $\pm 10\%$  line voltage fluctuation. To attain speed accuracy at 401-500, the line voltage cannot be lower than 5% of the rated voltage.**

<b>ELECTRICAL PROTECTION</b>		
<ul style="list-style-type: none"> <li>• Main fuse(s) in power entry module.</li> <li>• Control circuits provided with separate fuse.</li> </ul>		
<b>DIMENSIONS</b>		
<b>Width</b>	24 inches	48 cm
<b>Depth</b>	21¼ inches	55.5 cm
<b>Height (to platform surface)</b>	6⅞ inches	17 cm
<b>PLATFORM DIMENSIONS</b>		
	18 inches x 24 inches	46 cm x 61 cm
<b>CONSTRUCTION</b>		
<ul style="list-style-type: none"> <li>• Heavy gauge steel, phosphate-coated and texture-painted cabinet.</li> </ul>		
<b>WEIGHT</b>		
<b>Net</b>	80 lbs	36 kg
<b>Gross</b>	125 lbs	57 kg



Figure 23: Control Schematic, Quadrant A

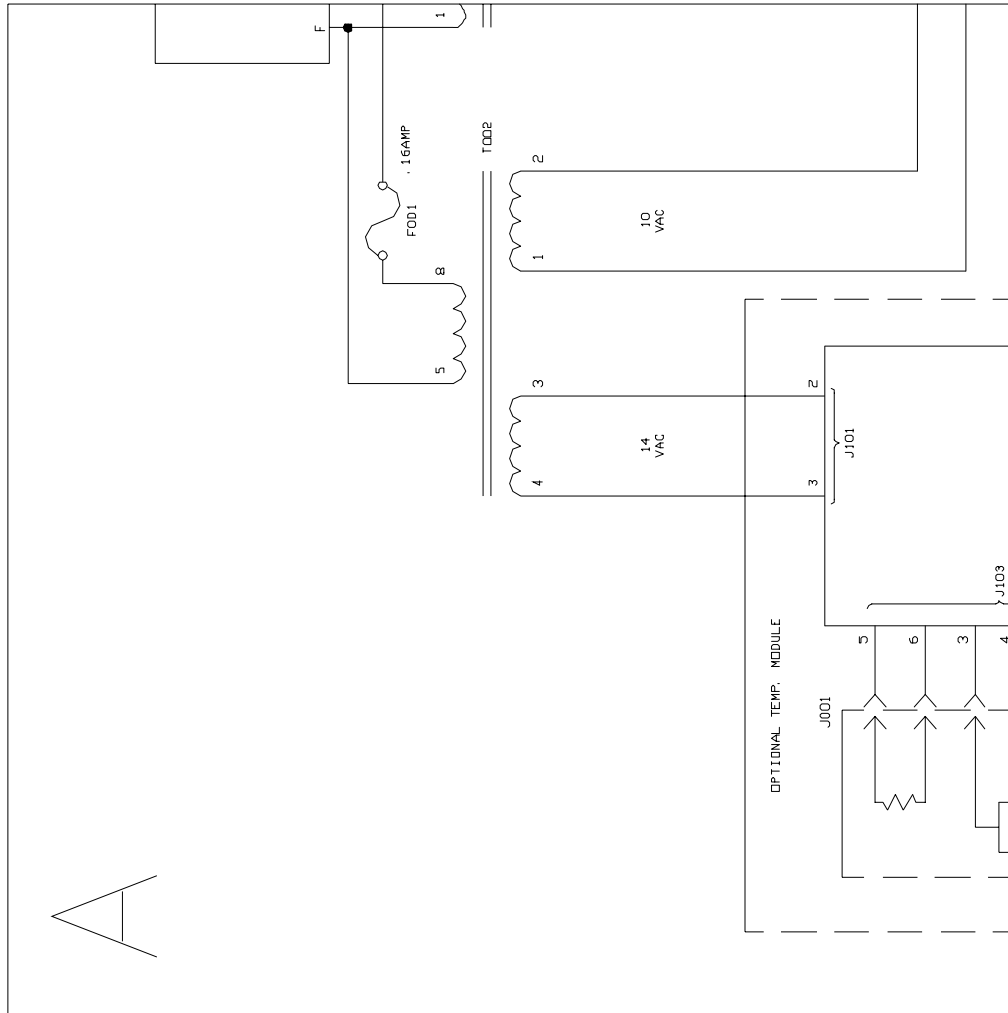

Figure 24: Control Schematic, Quadrant B

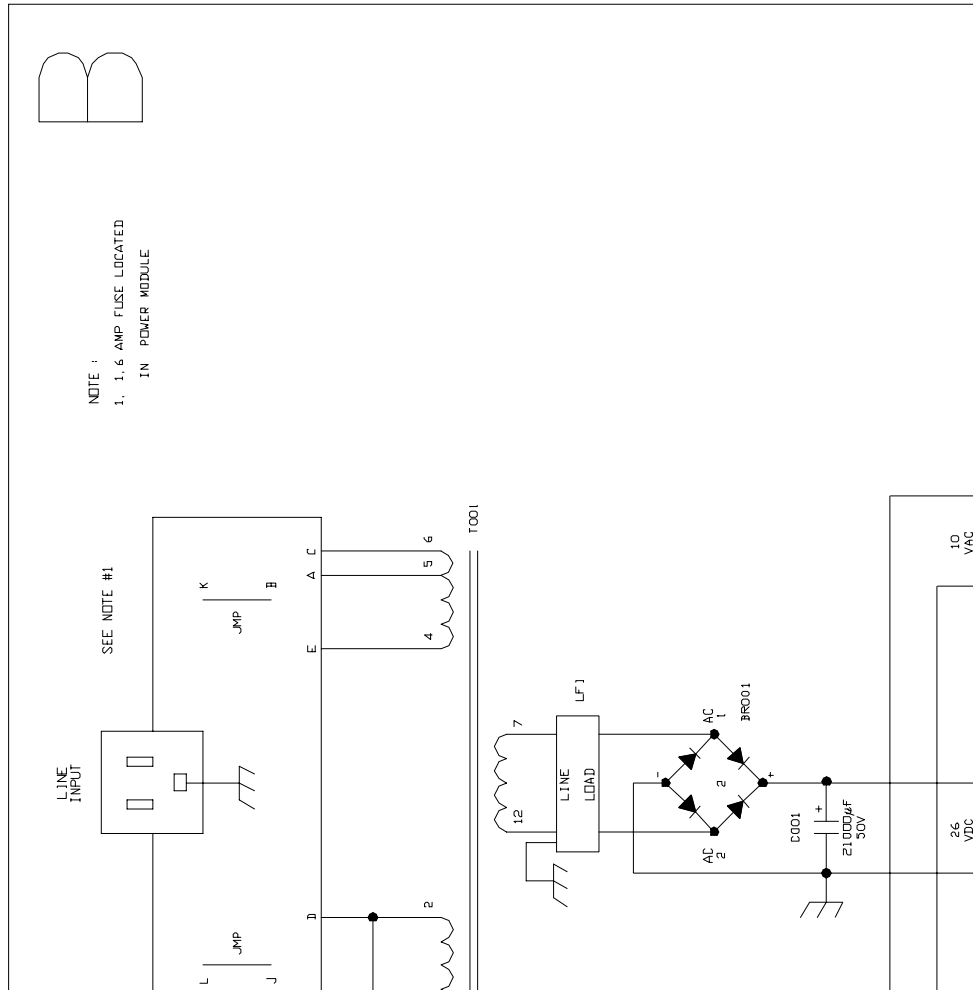

Figure 25: Control Schematic, Quadrant C

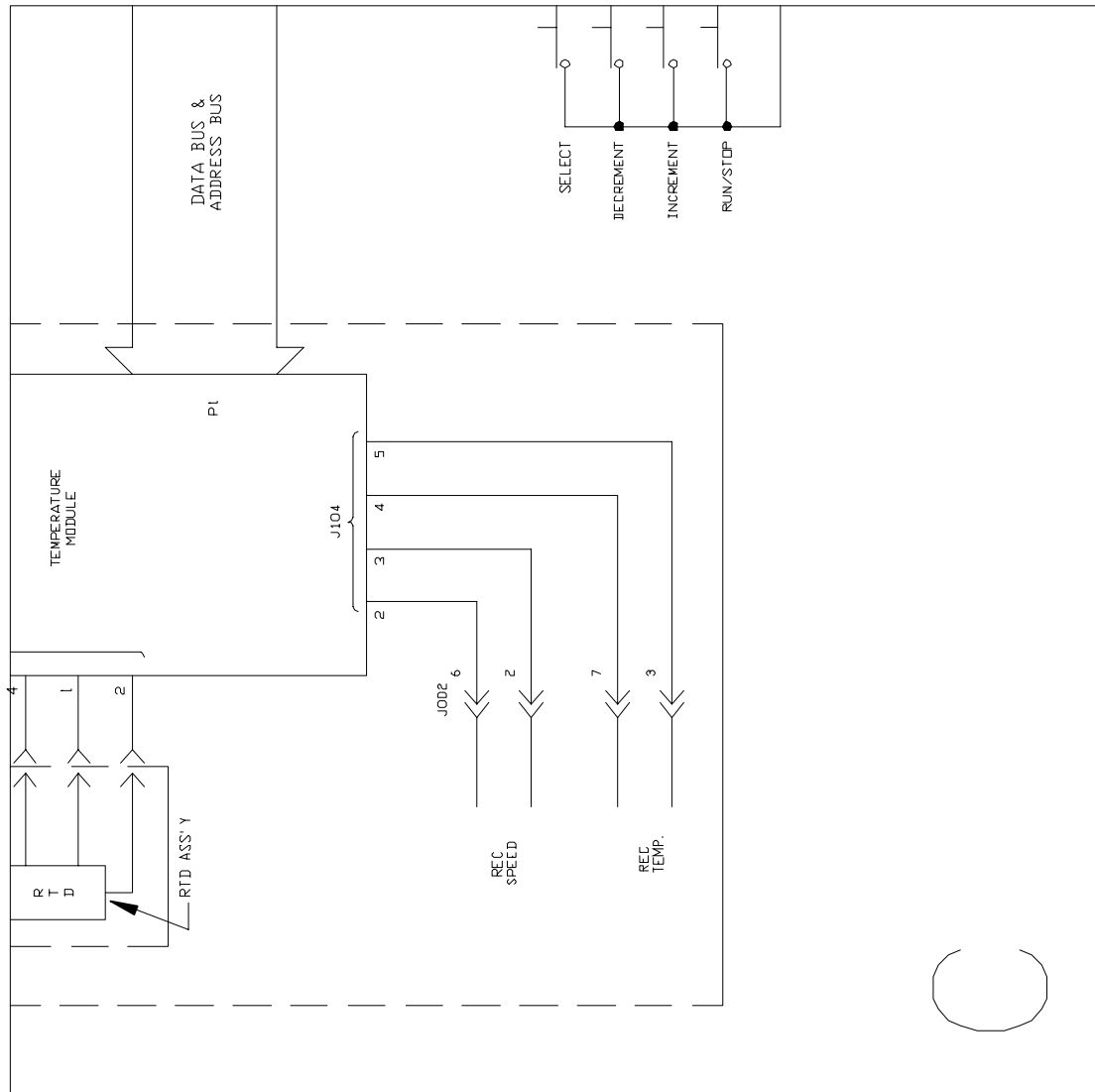
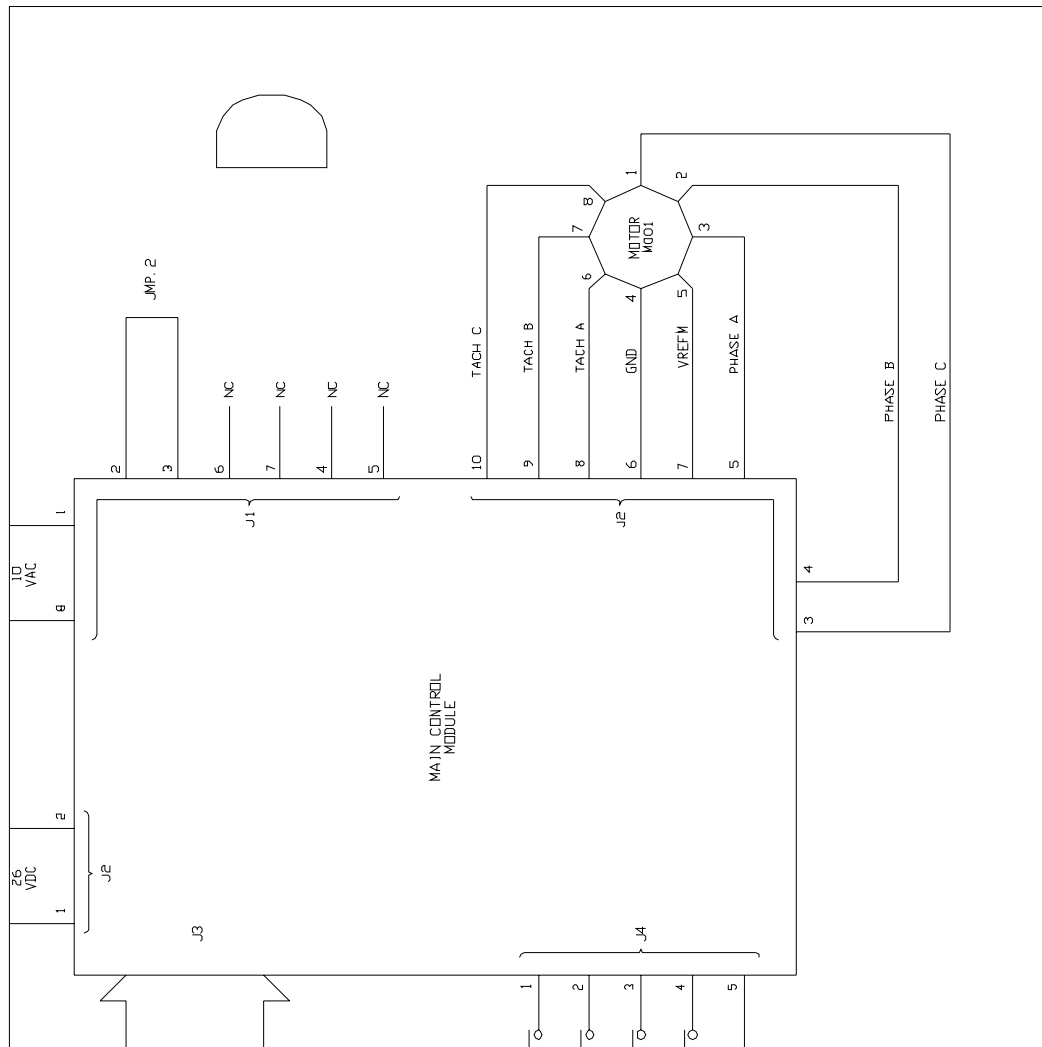



Figure 26: Control Schematic, Quadrant D



## 9.2 Drawing List

All drawings are valid for both the Innova 2100 and the Innova 2150, unless otherwise noted.

<b>Figure</b>	<b>Description</b>	<b>Page</b>
1	Front View	15
2	Rear View	16
3	Control Panel	17
4	Counterbalanced Drive Mechanism	20
5a	Space Requirements, Innova 2100	24
5b	Space Requirements, Innova 2150	24
6	2- to 6-Liter Clamp Installation	26
7	Recorder Connector	30
8	Power Entry Module	33
9	Voltage Selection	34
10	Indicator Pin & Alignment Arrow (Voltage Selection)	35
11	Power Module & Fuse Block	36
12	Fuse Block/Cover Assembly	36
13a	Double Fuse Arrangement	37
13b	Single Fuse Arrangement	37
14	Upper Bearing Housing & Extractor Plate Detail	38
15	Bearing Housing Assemblies (with extractor plate in place)	39
16	Eccentric Shafts & Pulley	40
17	Motor/Mounting Plate Assembly	41,42
18	Proper Harness Connection	43
19	Front Panel Assembly	44
20	Counterweight & Pulley Assembly	47
21	Outrigger Feet	48,49,51
22-26	Control Schematics	61-65

# 10 INDEX

**2**  
 2100 Specifications, 57, 58  
 2150 Specifications, 59, 60

## A

Accessory Flask Clamps  
 List of, 54  
 Alarms, 57, 59  
 Deactivating the, 28  
 Reactivating the, 29  
 Stopping the, 28  
 Ambient Operating Environment, 57, 59  
 Arrow Keys, 17  
 Automatic Restart Features, 57, 59

## B

Bearing Housing Retaining Straps, 23  
 Bearings, 20  
 Belt Adjustment, 40  
 Belt Replacement, 37

## C

Capacity Upgrade Option, 19, 46, 56  
 Installation of, 46  
 CAUTION  
 Symbol for, 7  
 Clamp Mounting Hardware, 54, 55  
 Clamps  
 Installation of, 26  
 Cleaning, 31  
 Construction Features, 58, 60  
 Continuous Run, 27  
 Control Panel, 16  
 Converting 2100 to 2150, 46  
 Copyright Notice, 7  
 Counterbalanced Drive Mechanism, 20

## D

Dimensions, 24

Disclaimer Notice, 7  
 Down Arrow Key, 17  
 Drawing List, 66  
 Drawings  
 2- to 6-Liter Clamp Installation, 26  
 Bearing Housing Assemblies, 39  
 Control Panel, 17  
 Control Schematic, 61, 62, 63, 64, 65  
 Counterbalanced Drive Mechanism, 20  
 Counterweight & Pulley Assembly, 49, 51  
 Double Fuse Arrangement, 37  
 Eccentric Shafts & Pulley, 40  
 Front Panel Assembly, 44, 46  
 Front View, 15  
 Fuse Block/Cover Assembly, 36  
 Index of, 66  
 Motor/Mounting Plate Assembly, 41, 42  
 Power Entry Module, 33  
 Power Module & Fuse Block, 36  
 Rear View, 16  
 Recorder Connector, 30  
 Single Fuse Arrangement, 37  
 Upper Bearing Housing & Extractor  
 Plate Detail, 38  
 Voltage Selection, 34  
 Voltage Selection Indicator Pin &  
 Alignment Arrow, 35  
 Drive Mechanism, 57, 59

## E

Electrical Protection, 58, 60  
 Electrical Service, 58, 59  
 Electronic Boards, 21  
*Err* in Display, 30  
 ESD Precautions, 45

## F

Features, 15  
 Flask Clamps  
 List of, 54

Function Indicator Lights, 18  
 Fuse Replacement, 33  
 Fuses, 35  
   Changing from Single to Double, 35

**H**

Heavy Duty Construction, 20

**I**

International Offices  
   List of, 3  
 Introduction, 13

**K**

Keypad, 17

**L**

LED Display, 17

**M**

MAINT Indicator, 29, 52  
 Maintenance, 31  
   Call for, 52  
 Manual Conventions, 7  
 Motor, 21, 58, 59  
 Motor Assembly Replacement, 41

**N**

NOTE  
   Symbol for, 7

**O**

On/Off Switch, 27  
 Outtrigger Kit  
   Installation of, 47  
 Overview, 13

**P**

Platform  
   Installation of, 25  
 Platform Assemblies, 18  
 Platforms  
   List of, 53  
 Power Cord Connection, 31

Power On, 27

**Q**

Quick Change Platform, 25, 56  
   Removal of, 50, 51  
 Quick Change Platform Option, 19  
   Installation of, 48, 50

**R**

Recorder, 29, 30, 43, 55  
   Connector Pin-out Diagram, 30  
 Remote Monitoring, 43  
 Remote Speed Monitoring, 57, 59  
 Replacing Electronic Boards, 45

**S**

Select Key, 17  
 Self-Diagnostic Status, 57, 59  
 Service  
   Important Warnings about, 33  
 Service Parts List, 53  
 Setpoint  
   Changing a, 28  
   Checking a, 27  
   Setting a, 27  
 Shaking Accuracy, 57, 59  
 Shaking Indication, 57, 59  
 Shaking Motion, 57, 59  
 Shaking Off, 27  
 Shaking On, 27  
 Shaking Setpoint & Control, 57, 59  
 Shaking Speed, 57, 59  
 Space Requirements, 23  
 Specifications  
   2100, 57, 58  
   2150, 59, 60  
 Start/Stop Key, 17  
 Status Indicator Lights, 18

**T**

Temperature Monitoring, 57, 59  
 Temperature/Monitor Option, 19, 29, 43, 55  
   Installation of, 44  
 Timed Functions, 28

- 
- Timer
- Cancelling the, 28
  - Features of, 57, 59
  - Setting the, 28
- Total Running Time, 29
- Triple Eccentric Drive, 20
- U**
- Universal Power Module, 16
- Unlimited Run, 27
- Unpacking, 23
- Up Arrow Key, 17
- User Interface Keys, 17
- V**
- Voltage Selection, 23
- Changing the, 34
- W**
- WARNING
- Symbol for, 7
- Warranty, 9
- Weight
- Gross, 58, 60
  - Net, 58, 60